

INSTALLATION INSTRUCTIONS

VIKING RANGE CORPORATION
111 Front Street
Greenwood, Mississippi 38930 USA
(662) 455-1200

DESIGNER SERIES CONVECTION MICROWAVE BUILT-IN TRIM KIT

Retain for Future Reference

IMPORTANT - PLEASE READ AND FOLLOW

- Before beginning, please read these instructions completely and carefully.
- Be sure to DISCONNECT THE PLUG of the microwave oven from the electrical outlet before installing the built-in trim kit. Remove the turntable from the oven cavity.
- Because the kit includes metal parts, caution should be used in handling and installation to avoid the possibility of injury.
- Do not remove permanently affixed labels, warnings, or plates from the product. This may void the warranty.
- Please observe all local and national codes and ordinances.
- The installer should leave these instructions with the consumer who should retain for local inspector's use and for future reference.

THIS BUILT-IN TRIM KIT IS DESIGNED FOR USE ONLY WITH VIKING CONVECTION MICROWAVE OVENS SPECIFYING BUILT-IN TRIM KIT DMTK276 OR DMTK306 FOR DESIGNER UNITS ON THE RATING LABEL ON THE BOTTOM FACE PLATE OF THE OVEN CAVITY.

IF YOUR LOWER CONVENTIONAL OVEN IS NOT LISTED IN THE USE AND CARE MANUAL OF THE MICROWAVE OVEN, THEN DO NOT INSTALL THE MICROWAVE OVEN ABOVE IT OR IN ANY AREA WHERE HEAT AND STEAM ARE GENERATED; FOR EXAMPLE, NEXT TO OR ABOVE A CONVENTIONAL RANGE.

PARTS INCLUDED IN THE KIT

1) Frame Assembly

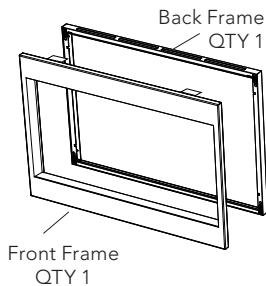

2) Bottom Duct Assembly
QTY 1

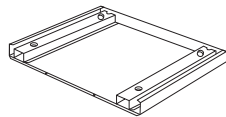

3) Screw A (1/2" length)
QTY 10



4) Screw B (1-3/4" length)
QTY 4



5) Screw C (3/4" length)
QTY 2



6) Duct A (1)
QTY 1

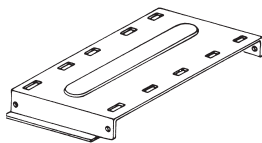

7) Duct A (2)
QTY 1

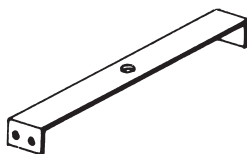

8) Duct A (3)
QTY 1

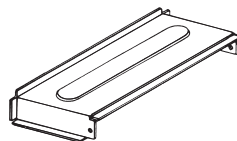

9) Duct B
QTY 1

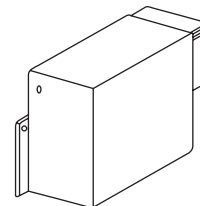

10) Duct C
QTY 1

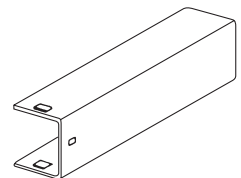

11) Template: QTY 1

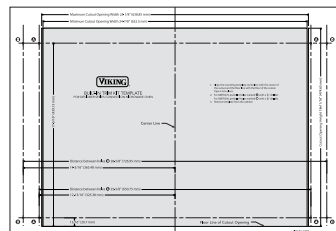

CABINET OR WALL CUTOUT

Provide an opening in the wall or cabinet as indicated in illustration 1. The depth should be a minimum of 20-1/8" (51.1 cm). The floor of the opening should be constructed of plywood strong enough to support the weight of the oven (about 100 lbs.) and should be level for proper operation of the oven .

NOTE: While the proper functioning of the oven does not require that the opening be enclosed (with sides, ceiling and rear partition), this may be required by local code, and it is suggested that the local code be checked for any such requirement.

ELECTRICAL OUTLET LOCATION

Outlet should NOT be in the shaded area as indicated on illustration 1. At the rear of the opening, provide a 3-pronged, polarized, electrical outlet, 115-120 volt AC, 15 amp or larger.

EXHAUST DUCT ASSEMBLY

1. Insert the edge of DUCT (B) into the hold lip of DUCT (C). Secure together by using a SCREW (A) provided in the kit. Remove the existing screw (#1) at upper right rear of the oven and secure DUCT (C) with the screw (#1) just removed from the oven. Secure DUCT (B) with SCREW (A) through the duct and into the original screw hole in the oven. See illustration 2.
2. Position DUCT (A)-1 on the top of the oven inserting edge of DUCT (BC) assembly into hole lip of DUCT (A)-1. Tighten two SCREWS (A), securing DUCT (A)-1 to DUCT (BC) assembly. See illustration 3.
3. Position DUCT (A)-2 on the top of the oven and insert it into the hold lip of DUCT (A)-1. Secure DUCT (A)-2 to DUCT (A)-1 using two SCREWS (A) provided. See illustration 4.
4. Position DUCT (A)-3 on top of the oven and insert it into DUCT (A)-2. Secure DUCT (A)-3 using three screws (A) provided. See illustration 5.

Illustration 1

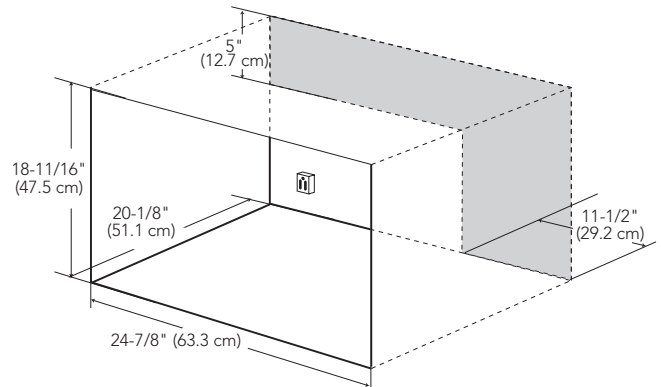

Illustration 2

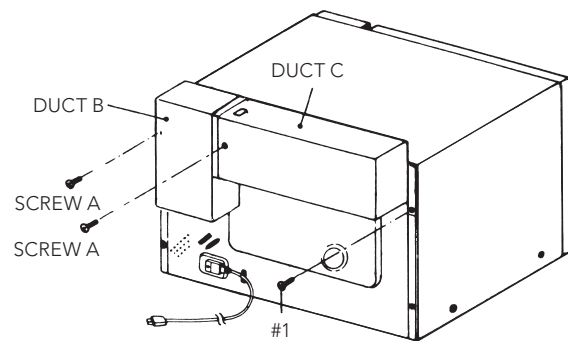

Illustration 3

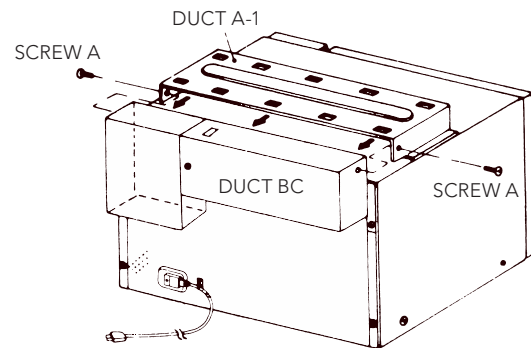

Illustration 4

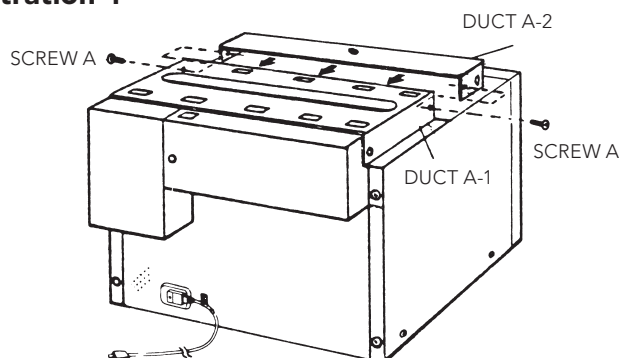
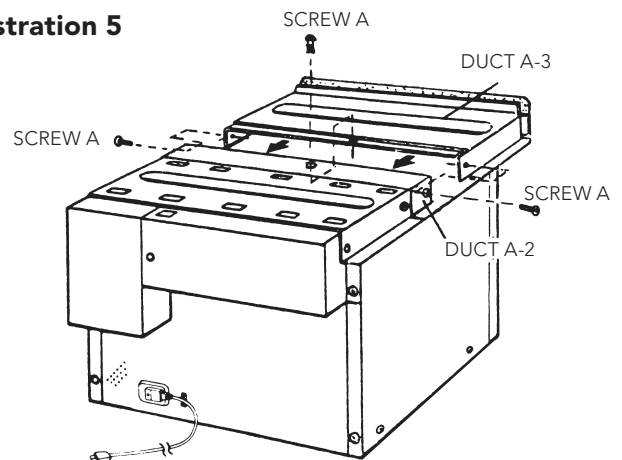

Illustration 5



MOUNTING TEMPLATE

1. Align the mounting template center line with the center of the cutout and the floor line with the floor of the cutout. Tape it into place.
2. For DMTK276, only predrill 4 holes marked "A" with a 1/16" drill bit. For DMTK306, only predrill 4 holes marked "B" with a 1/16" drill bit.
3. Remove template from the cabinet.

BOTTOM DUCT ASSEMBLY

1. Place the Bottom duct in the center of the opening so that gap "A" is equal to gap "B". When the BOTTOM DUCT ASSEMBLY is in the opening correctly, the bottom flange will fit tightly against the lower edge of the opening. See illustration 6.
2. Secure the BOTTOM DUCT ASSEMBLY with the two (3/4") SCREWS (C). **IMPORTANT:** Secure screws using holes on bottom flange.

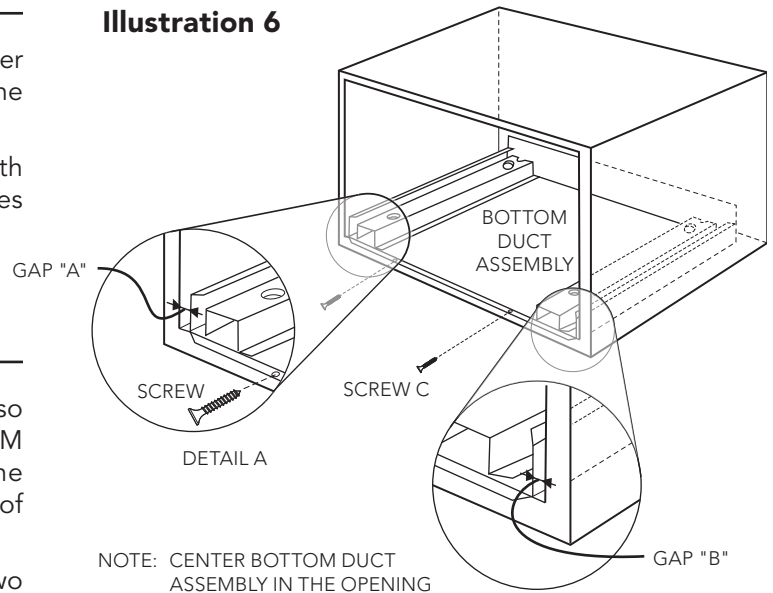

CABINET INSTALLATION

1. Place the oven adjacent to the wall or cabinet opening. Plug the power cord into the electrical outlet.
2. Carefully guide the assembled oven into the prepared opening. Slide the oven on the BOTTOM DUCT ASSEMBLY. See illustration 7. Avoid pinching the cord between the oven and the wall. Adjust the position of the oven so that the feet of the oven are fitted into the holes of the BOTTOM DUCT ASSEMBLY. See illustration 8.

FRAME INSTALLATION

Position the BACK FRAME to align with the predrilled holes that were drilled with the mounting template. Check that it is level and then secure with two SCREWS (B). See illustration 9. Secure the bottom portion of the BACK FRAME with the two remaining SCREWS (B).

Illustration 8

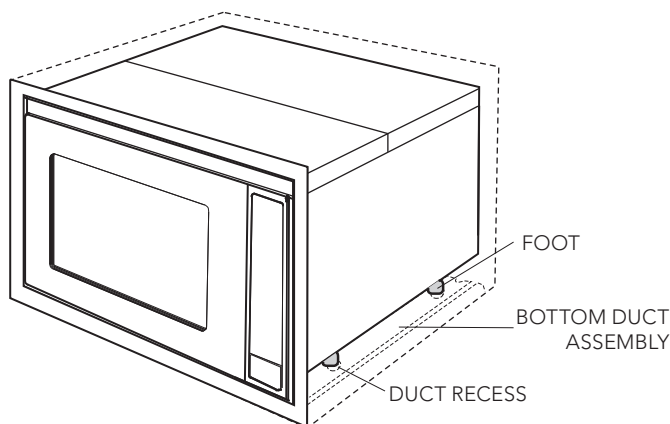

Illustration 7

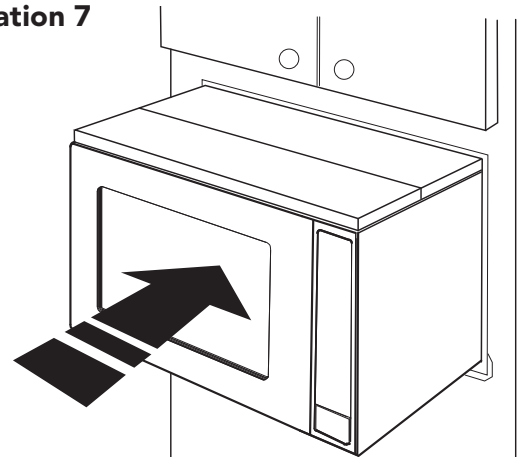
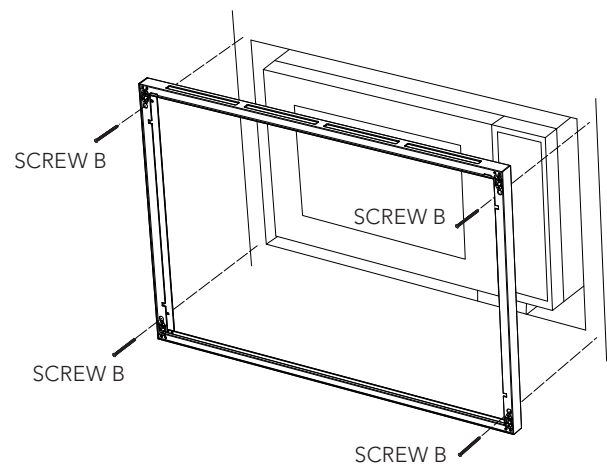

Illustration 9



FRAME INSTALLATION CONT.

Place the FRONT FRAME, with tabs on top, onto the BACK FRAME. Secure the FRONT FRAME to the BACK FRAME by firmly pushing the front frame onto the back frame engaging the four (4) snap attachments. See illustration 10.

Illustration 10

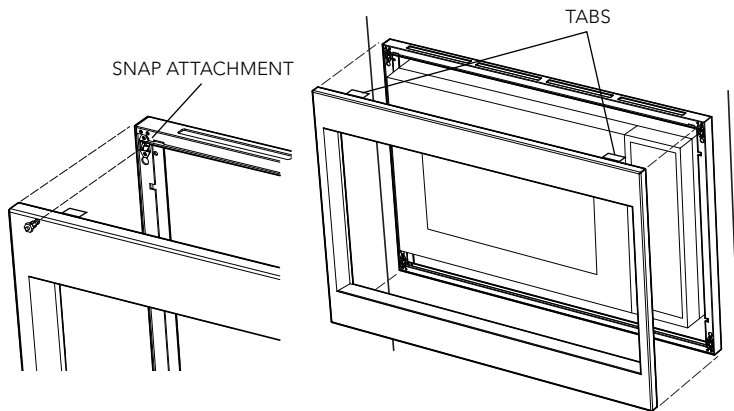

OVER OVEN INSTALLATION

Illustration 11

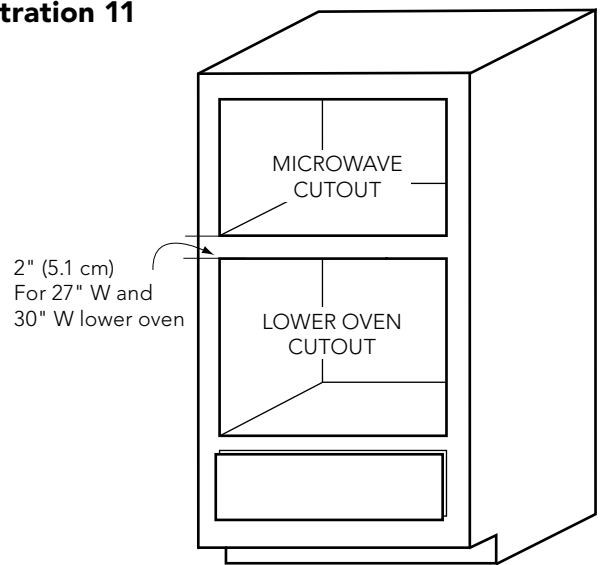

BASIC SPECIFICATIONS

	Microwave Oven		Built-In Designer Trim Kits	
	DMOC205		DMTK276	DMTK306
Overall Width	24-5/8"	(62.5 cm)	26-9/16"	(67.5 cm) 29-1/2" (74.9 cm)
Overall Height from Bottom	14-7/8"	(37.7 cm)	19-13/16"	(50.1 cm) 19-13/16" (50.1 cm)
Overall Depth from Rear	19"	(48.3 cm)	N/A	
Oven Interior	Width	16-1/8" (40.9 cm)	N/A	
	Height	9-5/8" (24.4 cm)		
	Depth	16-1/8" (40.9 cm)		
	Overall	1.5 cu. ft.		
Cutout Width	N/A		Min.	24-7/8" (63.3 cm)
Cutout Height	N/A		Min.	18-11/16" (47.5 cm)
Cutout Depth	N/A		Min.	20-1/8" (51.1 cm)
Electrical Requirements	120VAC/60 Hz (UL) 117VAC/60 Hz (CSA)		N/A	
Max. Amp Usage	1.55 KW	13 amps (UL)	N/A	
	1.5 KW	13 (CSA)		
Approx. Shipping Wt.	60 lbs.	(27.2 kg)	22.5 lbs.	(10.2 kg) 24 lbs. (10.9 kg)

Viking Range Corporation
111 Front Street • Greenwood, Mississippi (MS) 38930 USA • (662) 455-1200

Specifications subject to change without notice.

For more product information, call 1-888-VIKING1 (845-4641), or visit our web site at <http://www.vikingrange.com>