

Viking Use & Care Manual



Viking Range Corporation
111 Front Street
Greenwood, Mississippi 38930 USA
(662) 455-1200

For product information
call 1-888-VIKING1 (845-4641)
or visit the Viking Web site at
vikingrange.com

Congratulations

Your purchase of this product attests to the importance you place upon the quality and performance of the major appliances you use. With minimal care, as outlined in this guide, this product is designed to provide you with years of dependable service. Please take the few minutes necessary to learn the proper and efficient use and care of this quality product.

We appreciate your choosing a Viking Range Corporation product, and hope that you will again select our products for your other major appliance needs.

Table of Contents

Warnings	3
Important Safety Instructions	4
Cooking Utensils	6
Before Your Use Your New Rangetop	6
Using Your Rangetop	7
Cleaning and Maintenance	14
Power Failure	20
Service Information	21
Warranty	22

! WARNING
IF THE INFORMATION IN THIS MANUAL IS NOT FOLLOWED EXACTLY, A FIRE OR EXPLOSION MAY RESULT CAUSING PROPERTY DAMAGE, PERSONAL INJURY, OR DEATH.

Do not store or use gasoline or other flammable vapors and liquids in the vicinity of this or any other appliance.

WHAT TO DO IF YOU SMELL GAS

Do not try to light any appliance.
Do not touch any electrical switch; do not use any phone in your building.
Immediately call your gas supplier from a neighbor's phone.
Follow the gas supplier's instructions.
If you cannot reach your gas supplier, call the fire department.
Installation and service must be performed by a qualified installer, service agency, or the gas supplier.

! WARNING
Read all instructions before using the product. Install or locate the product only in accordance with the provided Installation Instructions.

! WARNING
NEVER use this appliance as a space heater to heat or warm the room. Doing so may result in carbon monoxide poisoning and overheating of the rangetop.

Important Safety Instructions

⚠ WARNING

To reduce the risk of fire, electrical shock, injury to persons, or damage when using the rangetop, follow basic precautions.

Including the following:

1. Your unit should be installed by a qualified technician. The appliance must be installed and electrically grounded according to local codes. Have this technician show the the location of the gas shut-off valve on the range so you know where and how to turn off the gas if necessary.
2. Do not attempt to repair or replace any part of this appliance unless specifically recommended in this manual. All servicing should be referred to a qualified technician. A qualified technician is required for any adjustments or conversions to Natural or Propane gas.
3. The "push-to-turn" knobs of this rangetop are designed to be child-safe. However, children should not be left alone in the kitchen while the range is in use. Do not store items of interest to children over the unit.

⚠ CAUTION

Children climbing to reach items could be seriously injured.

4. GREASE is flammable and should be handled carefully. Do not use water on grease fires. Never pick up a flaming pan. Smother flaming pan by covering utensil completely with well-fitting lid, cookie sheet or flat tray. Flaming grease outside of utensil can be extinguished with baking soda or, if available, a multi-purpose dry chemical or foam type extinguisher.
5. Never leave the surface area unattended at high heat setting. Boil-overs cause smoking and greasy spill-overs which may ignite.
6. If you are "flaming" liquor or other spirits under an exhaust, **TURN THE FAN OFF**. The draft could cause the flames to spread out of control.
7. Wear proper apparel. Loose-fitting or hanging garments should never be worn while using the appliance.
8. Never use your rangetop for warming or heating a room. This is based on safety considerations.
9. Use proper pan size. Select utensils having flat bottoms large enough to cover the burner. Using undersized utensils allows the flame to come up the side of the utensil, scorching the outside of the utensil and making cleanup harder.

10. The flame of the surface burner should be adjusted to just cover the bottom of the pan or pot. Excessive burner setting may cause scorching of adjacent countertop surfaces, as well as the outside of the utensil. This is based on safety considerations.
11. Use dry pot holders. Moist or damp pot holders on hot surfaces may result in burns from steam. Do not let potholder touch hot surface areas. Do not use a towel or other bulky cloth.
12. To reduce the risk of burns, ignition of flammable materials, and spillage due to unintentional contact with the utensil, the handle of a utensil should be positioned so that it is turned inward toward the center of the range, and so that it does not extend over adjacent burners.
13. Surface areas near burners may become hot enough to cause burns. During and after use, do not touch areas near burners until they have had sufficient time to cool.
14. Once the unit is installed as outlined in the Installation Instructions, it is important that the fresh air supply is not obstructed. The use of a gas cooking appliance results in the production of heat and moisture in the room in which it is installed. Ensure that the kitchen is well-ventilated. Keep natural venting holes open or install a mechanical ventilation device. Prolonged or intensive use of the appliance may call for additional (such as opening a window) or more effective ventilation (such as increasing the level of a mechanical ventilation if present).
15. The flueway must also remain clear.
16. Storage cabinet area above the unit must be 36" (91.4 cm) and cannot project more than 13" (33.0 cm) outward from the rear wall. Beware of potential hazards associated with retrieving items from such cabinets when the unit is in operation.
17. Keep area clean and free from combustible material, gasoline, and other flammable liquids.

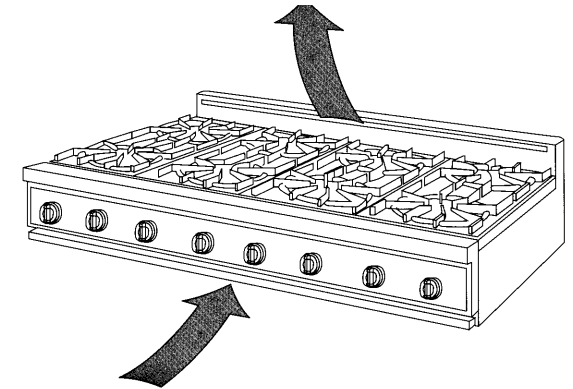

Cooking Utensils

Each cook has his or her own preference for the particular cooking utensils that are most appropriate for the type cooking being done. Any and all cooking utensils are suitable for use in the range and it is not necessary to replace your present domestic utensils with commercial cookware. This a matter of personal choice. As with any cookware, yours should be in good condition and free from excessive dents on the bottom to provide maximum performance and convenience. **NOTE: WHEN USING BIG POTS AND/OR HIGH FLAMES, IT IS RECOMMENDED TO USE THE FRONT BURNERS. THERE IS MORE ROOM IN THE FRONT AND POTENTIAL CLEANUP OF REAR OR APPLIANCE DUE TO STAINING OR DISCOLORATION WILL BE MINIMIZED.**

Before You Use Your New Rangetop

All products are wiped clean with solvents at the factory to remove any visible signs of dirt, oil, and grease which may have remained from the manufacturing process. Before starting to cook, clean the range thoroughly with hot, soapy water.

Steel Griddle/Simmer Plate (If applicable)

The griddle is a heavy-weight, polished steel griddle that has a USDA authorized protective coating. Before using, remove protective coating with room temperature club soda using a Scotch Brite® soft scour pad. It is very important to season the griddle by coating lightly with cooking oil.

Grill (If applicable)

The grates should be removed and washed in hot soapy water, rinsed and then replaced prior to use. Other grill parts should be removed, dusted, and replaced making sure that no flammable materials have been accidentally placed in the grill.

Drip Tray/Pan

The drip tray should be pulled out and checked for flammable materials. Make sure to unwrap the drip pan and replace it in its proper place under the griddle or grill (if applicable).

Wok Pan w/Lid (If applicable)

Remove all packaging materials and temporary labels from the wok. Clean thoroughly with hot soapy water and dry thoroughly. Apply a light coat of vegetable oil (do not use corn oil) to the entire inside surface with a paper towel. Heat the wok on medium setting until the cooking surface turns golden brown. Repeat this procedure several times. This seasoning seals the pores of the metal, keeps food from sticking, and prevents the wok from rusting. Wipe off excess oil before using or storing.

Using Your Rangetop

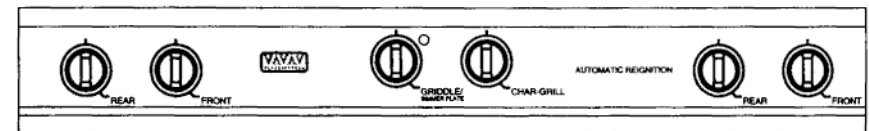

Lighting the Burners

Surface Burners-Automatic Re-ignition

To light the surface burners, turn the appropriate control knob counter clockwise to any position. This control is both a gas valve and an electric switch. Burners will ignite at any "on" position with the automatic re-ignition system. If the flame goes out for any reason, the burners will automatically re-ignite if the gas is still flowing. When gas is permitted to flow to the burners, the electric igniters start sparking. On all surface igniters you should hear a "clicking" sound. If you do not, turn off the control and check that the unit is plugged in and that the fuse or circuit breaker is not blown or tripped.

Within a few moments, enough gas will have traveled to the burner to be able to light. When the burner lights, turn the burner control to any position to adjust the flame size. Setting the proper height for the desired cooking process and selected utensil will result in superior cooking performance, while also saving time and energy.

In the event there is no electricity available, you can still use the surface burners by igniting them with a match.

Surface Cooking Tips

- Use low or medium flame heights when cooking in utensils that are poor conductors of heat, such as glass, ceramic, and cast-iron. Reduce the flame height until it covers approximately 1/3 of the utensil diameter. This will ensure more even heating within the utensil and reduce the likelihood of burning or scorching the food.
- Reduce the flame if it is extending beyond the bottom of the utensil. A flame that extends along the sides of the utensil is potentially dangerous, heats the utensil handle and kitchen instead of the food, and wastes energy.
- Reduce the flame height to the minimum level necessary to perform the desired cooking process. Remember that food cooks just as quickly at a gentle boil as it does at a rolling boil. Maintaining a higher boil that is necessary wastes energy, cooks away moisture, and causes a loss in food flavor and nutrient level.

TEMPERATURE SETTING GUIDELINES*

<u>HEAT SETTING</u>	<u>USE</u>
Simmer	Melting small quantities. Steaming rice.
HI-Simmer	Simmering small quantities, sauces.
Low	Melting large quantities
Low - Med	Low-temperature frying. (eggs, etc.) Simmering large quantities Heating milk, cream sauces, gravies, puddings.
Med	Sauteing and browning Braising, pan-frying Maintaining slow boil on large quantities.
Med-HI	High-temperature frying. Pan broiling Maintaining fast boil on large quantities
HI	Boiling water quickly. Deep-fat frying in large utensil

*NOTE: The above information is given as guide only. You may need to vary the heat settings to suit your personal requirements.

Using the Trivet Grate (Center Wok Grate)

The trivet grate converts the large burner grate to a grate suitable for use with large stock pots. To use the trivet grate, place the small grate in the center of the large grate. Turn the trivet grate until the feet on the trivet grate rests inside the notches located on the center ring of the large grate.

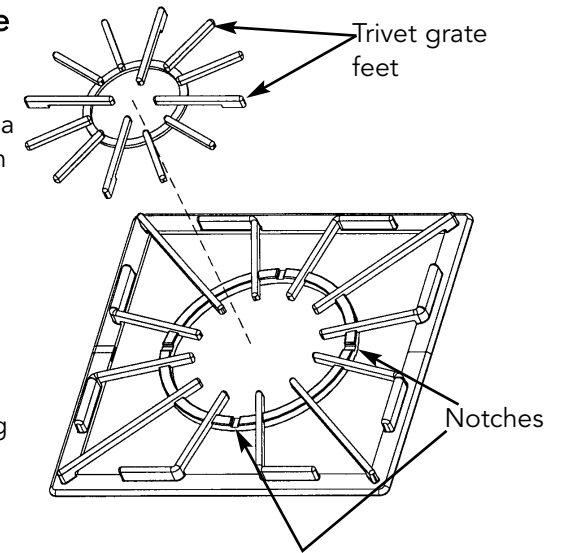

Griddle/Simmer Plate

Turning the thermostat counter clockwise to any "on" position activates a glo-bar igniter and opens an electromechanical valve in the system to start the gas valve. The griddle has a power "ON" light which glows when the griddle thermostat is turned on. The light cycles on and off with the burner.

Griddle/Simmer Plate Operation

- Turn the griddle control knob to desired temperature setting. Wait until light cycles off for indication that the desired temperature has been reached.
- Always turn off when not in use, or lower the heat between cooking loads.

Cooking Tips

- Use liquid cooking oil, cooking sprays, or butter for eggs, pancakes, French toast, fish and sandwiches. This will help to reduce sticking. Meats usually have enough natural oils.
- Remove food particles with a metal spatula during cooking to make the cleanup easier and to avoid including those particles in the food.
- Do not overheat the griddle. Turn it off when not in use, or lower heat between cooking loads.
- After using and cleaning the griddle, the surface should be wiped with a light film of cooking oil to protect the finish from rust and corrosion.

Griddle Cooking Chart

Food	°F	°C
Eggs	250-300	121-149
Bacon	325-350	163-177
Pancakes	375-400	191-205
French Toast	400	205
Fish Fillets	300	149
Hamburger	350	177
Steaks	350	177

Grill Operation

- Turn on kitchen ventilation product.
- Turn control knob to HI.
- Preheat on HI for 5 to 10 minutes.
- Place food on grill, cook as desired.

Grill Cooking Tips

- When grilling chicken, roasts, well done steaks or chops and thick pieces of meat, sear on HI. Then, reduce the heat setting to prevent excessive flare-up. This will allow the food to cook through without burning the outside.
- After steaks, chops, or hamburgers have been allowed to sear for approximately 1 minute, you may slide a spatula under the meat and turn it approximately 90° so that a waffle pattern will be seared onto the food.
- Use a metal spatula instead of tongs or a fork to turn the meat. A spatula will not puncture the meat allowing juices to escape.
- Turn the meat over only once. Juices are lost when steaks, chops or hamburgers are turned several times. The best time to turn the meat is after the juices have begun to bubble to the surface.
- To test for doneness, make a small slash in the center of the meat, not the edge. This will prevent loss of juices.
- Occasionally there may be flare-ups or flames above the grill due to drops of fat falling onto the flame spreader. It is normal to have some flare-up during grilling. Use a long handled spatula to move food to another area until the flames subside.

Grill Cooking Chart

FOOD	WEIGHT OR THICKNESS	FLAME SIZE	TOTAL SUGGESTED COOKING TIME	SPECIAL INSTRUCTIONS AND TIPS
Beef Hamburger	1/2-3/4" (1.3-1.9cm)	Med	8-15 minutes	Grill, turning once when juices rise to the surface. We recommend that ground chuck be used for hamburgers, as it will give you a juicier hamburger than ground round. Do not leave hamburgers unattended since a flare-up could occur quickly.
Steaks Rib, Club, Porterhouse, T-Bone Sirloin	Rare 1"(2.5 cm) (140°F/60°C)	High	8-12 minutes	Remove excess fat from edge. Slash remaining fat at 2" (5.1 cm) intervals to keep edges from curling. Grill, turning once.
	1 1/2" (3.8 cm)	High	11-16 minutes	
Medium (160°F/71°C)	1"(2.5 cm)	Med	12-20 minutes	
	1 1/2" (3.8 cm)	to High	16-25 minutes	
Well-done (170°F/77°C)	1"(2.5 cm)	Med	20-30 minutes	
	1 1/2" (3.8 cm)	to High	25-35 minutes	
Tenderloin	5 pounds (2.3 kg)	High	30-40 minutes	Remove surface fat and connective tissue. Fold over thin end to form uniformly thick piece. Bind with string. Grill turning to brown evenly. Brush often with melted butter, margarine or oil. Cook until rare.

Grill Cooking Chart

FOOD	WEIGHT OR THICKNESS	FLAME SIZE	TOTAL SUGGESTED COOKING TIME	SPECIAL INSTRUCTIONS AND TIPS
MEATS Pork Chops	1/2" (1.3 cm)	Med	20-40 minutes	Remove excess fat from edge. Slash remaining fat at two-inch intervals to keep edges from curling. Grill, turning once, and moving if necessary. Cook well done.
	1" (2.5cm)	Med	35-60 minutes	
	Ribs	Med	45-60 minutes	
	Ham Steaks (fully cooked)	1/2" (1.3 cm)	High	
Hot Dogs		Med	5-10 minutes	Slit skin before cooking. Grill, turning once.
POULTRY Chicken Broiler/Fryer Halves or Quarters	2-3 pounds (.9-1.4 kg)	Low or	1-1 1/2 hours	Place skin side up. Grill, turn, and brush frequently with melted butter, margarine, oil, or marinade.
		Med	40-60 minutes	
FISH AND SEAFOOD	Steaks Halibut Salmon Swordfish 3/4"-1" (1.9-2.5 cm)	Med to High	8-15 minutes	Grill, turning once; brush with melted butter, margarine, or oil to keep fish moist.

Cooking Substitute Charts

In many cases, a recipe requires an ingredient which is not readily available or calls for a unit of measure that is not easily recognized. The following charts have been provided as useful guides in these situations.

Ingredient Substitutes	
Recipe calls for:	Use:
1 Tbsp. cornstarch	2 Tbsp. flour (thickening)
1 whole egg	2 egg yolks plus 1 Tbsp. water
1 c. whole milk	1 c. skim milk plus 2 Tbsp. margarine or 1/2 c. evaporated milk plus 1/2 c. water
1 oz unsweetened chocolate	3 Tbsp. cocoa powder plus 1 Tbsp. margarine
1 Tbsp. baking powder	1/2 tsp. cream of tartar plus 1/4 tsp. baking soda
1/2 c. butter	7 Tbsp. margarine or shortening
1 c. dairy sour cream	1 Tbsp. lemon juice plus 1 c. evaporated milk

Canned Food Sizes			
Sizes	Contents	Sizes	Contents
8 oz	1 cup	No. 303	2 cups
Picnic	1 3/4 cups	No. 2	2 1/2 cups
No. 300	1 3/4 cups	No. 3	4 cups
No. 1 tall	2 cups	No. 10	12 cups

Kitchen Equivalents and Metrics

Measure	Equivalent	Metric*
1 tablespoon	3 teaspoons	15 mL
2 tablespoons	1 ounce	30 mL
1 jigger	1 1/2 ounces	45 mL
1/4 cup	4 tablespoons	60 mL
1/3 cup	5 tbsp. plus 1 tsp.	80 mL
1/2 cup	8 tablespoons	125 mL
1 cup	16 tablespoons	250 mL
1 pint	2 cups	30 grams
1 pound	16 ounces	450 grams
2.21 pounds	35.3 ounces	1 kilogram

*Rounded for easier measuring

Cleaning and Maintenance

Any piece of equipment works better and lasts longer when maintained properly and kept clean. Cooking equipment is no exception. Your rangetop must be kept clean and maintained properly. Make sure all controls are in the "OFF" position before cleaning. Disconnect power if you are going to clean thoroughly with water.

Open Surface Burners (If applicable)

Wipe up spill-overs as soon as possible after they occur and before they get a chance to burn in and cook solid. In the event of a spill-over, follow these steps:

1. Allow the burner and grate to cool to a safe temperature level.
2. Lift off the burner grates.
3. If the spill is contained in the bowl of the grate support, just remove the bowl and clean in warm soapy water.
4. Lift the grate support off.
5. Wash these parts in hot, soapy water and rinse clean.
6. If the spill has gone lower than the grate supports, draw out the drip pan and wash with hot, soapy water.

If ports on the burners are clogged, clean with a straight pin. **DO NOT** enlarge or distort the ports. **DO NOT** use a toothpick to clean the ports. Make sure burner cap is level. Occasionally check the burner for proper size and shape. If flames lift off ports, are yellow, or are noisy when turned on, you may need to clean the burners or call a qualified technician for adjustments.

Sealed Surface Burners (If applicable)

Wipe up spill-overs as soon as possible after they occur and before they get a chance to burn in and cook solid. In the event of a spill-over, follow these steps:

1. Allow the burner and grate to cool to a safe temperature level.
2. Lift off the burner grate. Wash in warm, soapy water.
3. Remove the burner cap and burner head and clean, per instructions below.
4. Wipe up an spills which remains on the sealed top surface.
5. Replace burner cap, burner head and grates after drying thoroughly.

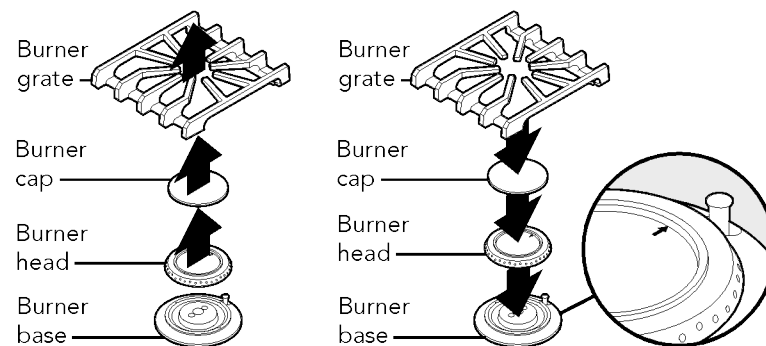

Note: When replacing burner head, arrow must be pointing towards back of range.

If ports on the open or sealed burners are clogged, clean with a straight pin. **DO NOT** enlarge or distort the ports. **DO NOT** use a toothpick to clean the ports. When replacing burner head, carefully align the tabs underneath the cap with the outside edge of burner. Make sure the tabs are not aligned with the igniter and the burner cap is level.

Sealed Burner Aluminum Base (If applicable)

The aluminum base should be wiped regularly with hot soapy water at the end of each cooling period. **Do not use** steel wool, abrasive cloths, cleanser, or powders. To remove encrusted materials, soak the area with hot towel to loosen the material, then use a wooden or nylon spatula. **Do not use** a metal knife, spatula, or any other material tool to scrape the aluminum base.

NOTE: For stubborn stains, use non-abrasive cleanser such as Bon Ami™ and a soft brush or soft Scotch Brite™ pad.

Burner Caps

The surface burner caps should be routinely removed and cleaned. Always clean the burner caps after a spill over. Keeping the burner caps clean will prevent improper ignition and uneven flames. To clean, pull burner cap straight up from the burner base. Wipe off surface burner caps with warm, soapy water and a soft cloth after each use. Use a non-abrasive cleanser such as Bon Ami™ and a soft brush or soft Scotch Brite™ pad for cooked-on foods. Dry thoroughly after cleaning. For best cleaning and to avoid possible rusting, do not clean in dishwasher or self-cleaning oven. When replacing burner caps, carefully align the tabs underneath the cap with the outside edge of burner. Make sure burner cap is level.

Wok Cast Iron Burner (If applicable)

For proper lighting and performance of the burner, keep the electric igniter and burner ports clean. It is necessary to clean these only when the flame does not burn blue completely around all rings of the burner, when there is a severe spillover or when the burner does not light, even though the electric spark igniter sparks. Clean the burner by scraping off burned on food soil. Use a wire, a straightened paper clip, or needle to clean the ports. **Do not use a toothpick; it could break off in the port. Be sure the venturi tube remains dry.**

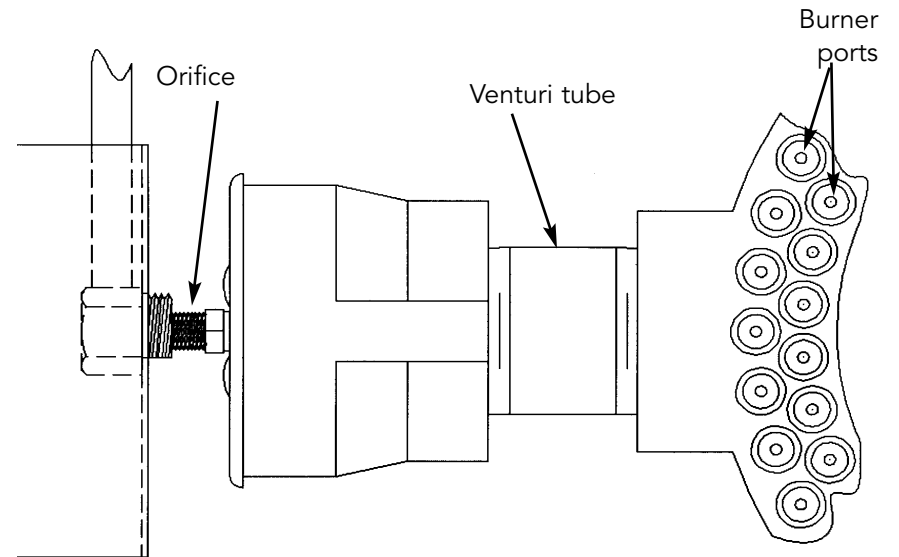

Wok Pan w/Lid (If applicable)

Wash the wok after each use in hot, soapy water. Do not use harsh abrasives or scouring pad as they can harm the protective seasoning. Dry thoroughly. Apply a light coat of cooking oil to the inside surface with a paper towel. Place over medium heat for 15 - 30 seconds. Remove from heat and allow to cool. Wipe off excess oil before storing in an inside cabinet. **Do not store the wok pan and lid outdoors.**

Griddle/Simmer Plate

1. After using the griddle, always remove the drip pan located below it by pulling the drip pan toward you. The drip pan needs to be cleaned after each use of the griddle. Cooked-off grease will drain from the griddle through the drain tube and accumulate in the drip pan. Wash in hot soapy water or with an antibacterial cleaner. The drip pan needs to be cleaned after each use. If grease is permitted to accumulate, fire hazard could occur, since the griddle burners are directly above the pan.
2. Rub the surface of a hot griddle with unsalted solid shortening, vegetable oil or spray it with a non-stick cooking spray. Thoroughly wipe it with a burlap or another rough cloth to remove food particles and other residue.
3. Stubborn spots may be removed by rubbing the surface with a rough grained nylon scrubbing pad with cooking oil. If necessary, flush the surface of a warm griddle (200°F/93°C) with club soda and wipe over entire surface with a paper towel. Coat lightly with cooking oil.
4. Special griddle cleaners are commercially available which may be used to remove heavy soil build-up. Follow manufacturer's directions exactly. Rinse the griddle with room temperature club soda after using these cleaners. Dry and coat lightly with cooking oil. Use griddle stones only when absolutely necessary and then with extreme caution. Wipe away any griddle-stone dust and food particles and coat lightly with cooking oil.
5. Using hot soapy water to clean the griddle will remove the cooked-in seasoning and will require re-seasoning by coating lightly with cooking oil.
6. **Never flood a hot griddle with cold water!** This promotes griddle warping and can cause the griddle plate to crack if continued over a period of time.

Grill

The grill grate may be cleaned immediately after cooking is complete and before turning off the flame. Wearing a barbecue mitt to protect your hand from heat, use a soft bristle barbecue brush to scrub the grill grate. Dip the brush frequently in a bowl of water. Steam is created as the water contacts the hot grate. The steam assists the cleaning process by softening the food particles. For thorough cleaning of the grill grate, soak 15 to 30 minutes in a hot water and detergent solution. After soaking, scrub with a soft scotch brite pad. **DO NOT USE** a steel wool pad or abrasive cleaners. They could damage the porcelain finish.

To disassemble for thorough cleaning, remove parts after they have cooled in the following order:

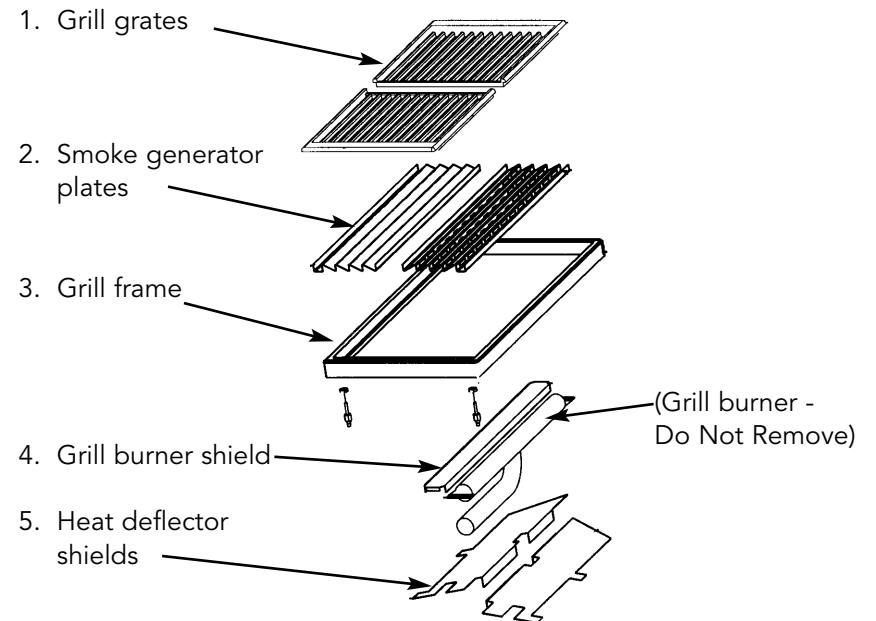

Clean greasy parts with a household grease solvent such as household ammonia and water. If necessary, a soap filled steel wool pad can be used on the grill frame shield, grill burner, and grill heat deflector.

After using the grill, always remove the drip pan located below it by pulling the drip pan toward you. The drip pan needs to be cleaned after each use of the grill. Cooked-off grease will drain from the grill through the drain tube and accumulate in the drip pan. Wash in hot soapy water or with an antibacterial cleaner. The drip pan needs to be cleaned after each use. If grease is permitted to accumulate, fire hazard could occur, since the grill burners are directly above the pan.

Control Knobs

MAKE SURE THE CONTROL KNOBS POINT TO THE OFF POSITION BEFORE REMOVING. Pull the knobs straight off. Wash in detergent and warm water. Do not soak knobs. Dry completely and replace by pushing firmly onto stem. **DO NOT USE** any cleaners containing ammonia or abrasives. They could remove the graphics from the knob.

Control Panel

DO NOT USE any cleaners containing ammonia or abrasives. They could remove the graphics from the control panel. Use hot, soapy water and a soft clean cloth.

Stainless Steel Parts

All stainless steel parts should be wiped regularly with hot, soapy water at the end of each cooling period and with liquid stainless steel cleaner when soapy water will not do the job. **Do not use** steel wool, abrasive cloths, abrasive cleaners, or powders. If necessary to scrap stainless steel to remove encrusted materials, soak the area with hot towels to loosen the material, then use a wooden or nylon spatula or scraper. **Do not use a metal knife, spatula, or any other metal tool to scrape stainless steel.** For occasional heavy cleaning use, a cleaner such as Liquid Zud can be used according to package directions. Do not permit citrus or tomato juice to remain on stainless steel surface, as citric acid will permanently discolor stainless steel. Wipe up any spills immediately.

Brass Parts

CAUTION: All brass special ordered parts are coated with an epoxy coating. **DO NOT USE BRASS OR ABRASIVE CLEANERS ON THE BRASS OPTION PARTS.** All brass parts should be wiped regularly with hot soapy water.

Power Failure

If power failure occurs, the electric ignitors will not work. The rangetop surface burners can still be used, but only when the burners are lit manually with a match. The griddle cannot be used at all.

Due to safety considerations and the possibility of personal injury in attempting to light and extinguish the burner, the grill should, under no circumstances, be used during a power failure. The grill burner control should always remain in the "OFF" position during a power failure. Momentary power failure can occur unnoticed. The rangetop is affected only when the power is interrupted. When it comes back on, the rangetop will function properly without any adjustments. A "brown-out" may or may not affect range operation, depending on how severe the power loss is.

Service Information

If service is required after checking the troubleshooting guide:

1. Call your dealer or authorized service agency. The name of the authorized service agency can be obtained from the dealer or distributor in your area.
2. Have the following information readily available:
Model Number
Serial Number
Date of Purchase
Name of dealer from whom purchased
3. Clearly describe the problem that you are having.

If you are unable to obtain the name of an authorized service agency, or if you continue to have service problems, contact Viking Range Corporation at (888) 845-4641 or write to:

VIKING PREFERRED SERVICE

111 Front Street
Greenwood, Mississippi (MS) 38930 USA

Record the following information indicated below. You will need it if service is ever required. The serial number and model number for your rangetop is located on the left rear side of the burner box.

Model Number _____ Serial Number _____

Date of Purchase _____ Date Installed _____

Dealer's Name _____

Address _____

If service requires installation of parts, use only authorized parts to ensure protection under the warranty.

Please retain the manual for future reference.

VGRT PROFESSIONAL SERIES BUILT-IN GAS RANGETOP WARRANTY

ONE YEAR FULL WARRANTY

Built-in gas rangetops and all of their component parts, except as detailed below*, are warranted to be free from defective materials or workmanship in normal household use for a period of twelve (12) months from the date of original retail purchase. Viking Range Corporation, warrantor, agrees to repair or replace, at its option, any part which fails or is found to be defective during the warranty period.

*Painted and decorative items are warranted to be free from defective materials or workmanship for a period of ninety (90) days from the date of original retail purchase. ANY DEFECTS MUST BE REPORTED TO THE SELLING DEALER WITHIN NINETY (90) DAYS FROM DATE OF ORIGINAL RETAIL PURCHASE.

Viking Range Corporation uses the most up-to-date processes and best materials available to produce all color finishes. However, slight color variation may be noticed because of the inherent differences in painted parts and porcelain parts as well as differences in kitchen lighting, product locations, and other factors.

FIVE YEAR LIMITED WARRANTY

Any surface burner, griddle tubular burner, or grill tubular burner which fails due to defective materials or workmanship in normal household use during the second through fifth year from the date of original retail purchase will be repaired or replaced, free of charge for the part itself, with the owner paying all other costs, including labor.

NINETY (90) DAY RESIDENTIAL PLUS WARRANTY This warranty applies to applications where use of the product extends beyond normal residential use. Examples are, but not limited to, bed and breakfasts, fire stations, private clubs, churches, etc. This warranty excludes all commercial locations such as restaurants, food service locations, and institutional food service locations.

This warranty extends to the original purchaser of the product warranted hereunder and to each transferee owner of the product during the term of the warranty.

This warranty shall apply to products purchased and located in the United States and Canada. Products must be purchased in the country where service is requested. Warranty labor shall be performed by an authorized Viking Range Corporation service agency or representative. Warranty shall not apply to damage resulting from abuse, accident, natural disaster, loss of electrical power to the product for any reason, alteration, outdoor use, improper installation, improper operation, or repair or service of the product by anyone other than an authorized Viking Range Corporation service agency or representative. This warranty does not apply to commercial usage. Warrantor is not responsible for consequential or incidental damage whether arising out of breach of warranty, breach of contract, or otherwise. Some jurisdictions do not allow the exclusion or limitation of incidental or consequential damages, so the above limitation or exclusion may not apply to you.

Owner shall be responsible for proper installation, providing normal care and maintenance, providing proof of purchase upon request, and making the appliance reasonably accessible for service. If the product or one of its component parts contains a defect or malfunction during the warranty period, after a reasonable number of attempts by the warrantor to remedy the defects or malfunctions, the owner is entitled to either a refund or replacement of the product or its component part or parts. Warrantor's liability on any claim of any kind, with respect to the goods or services covered hereunder, shall in no case exceed the price of the goods or service or part thereof which gives rise to the claim.

WARRANTY SERVICE: Under the terms of this warranty, service must be performed by a factory authorized Viking Range Corporation service agent or representative. Service will be provided during normal business hours, and labor performed at overtime or premium rates shall not be covered by this warranty. To obtain warranty service, contact the dealer from whom the product was purchased, an authorized Viking Range Corporation service agent, or Viking Range Corporation. Provide model and serial number and date of original purchase. For the name of your nearest authorized Viking Range Corporation service agency, call the dealer from whom the product was purchased or Viking Range Corporation. **IMPORTANT:** Retain proof of original purchase to establish warranty period.

The return of the Owner Registration Card is not a condition of warranty coverage. You should, however, return the Owner Registration Card so that Viking Range Corporation can contact you should any question of safety arise which could affect you.

Any implied warranties of merchantability and fitness applicable to the above described surface burner, griddle tubular burner, or grill tubular burner are limited in duration to the period of coverage of the applicable express written limited warranties set forth above. Some jurisdictions do not allow limitations on how long an implied warranty lasts, so the above limitation may not apply to you. This warranty gives you specific legal rights, and you may also have other rights which may vary from jurisdiction to jurisdiction.

Specifications subject to change without notice.