



### Standard Features & Accessories

#### All models include

- Right oven—large convection cavity
  - Overall capacity—4.1 cu. ft. (23"W. x 16-1/8"H. x 18-3/4"D.)
  - AHAM Standard capacity—3.7 cu. ft. (23"W. x 16-1/8"H. x 17"D.)
  - **Exclusive** combination of single u-shaped bake burners and infrared broil burner, all with electric spark ignition
  - Three heavy-duty racks/six rack positions
- Left oven—bake, with auto. ignition
  - Overall capacity—2.1 cu. ft. (12-1/8"W. x 16-1/8"H. x 18-3/4"D.)
  - AHAM Standard capacity—2.0 cu. ft. (12-1/8"W. x 16-1/8"H. x 18-1/8"D.)
  - Two heavy-duty racks/six rack positions
- **Exclusive** VariSimmer™ setting for all burners

- Removable porcelain burner bowls
- Drip tray with roller bearing glides and two-quart drip pan
- Six functions—natural airflow bake, convection bake, infrared broil, convection infrared broil, convection dehydrate, and convection defrost
- Standard kickspace height

#### 6G models include

- Six 15,000 BTU stainless steel burners with porcelain/cast iron caps and automatic ignition/re-ignition
- 12" width thermostatically controlled steel griddle/simmer plate

#### 6Q models include

- Six 15,000 BTU stainless steel burners with porcelain/cast iron caps and automatic ignition/re-ignition

- 12"W. grill with flavor generator plates and automatic ignition/re-ignition

#### 4G models include

- Four 15,000 BTU stainless steel burners with porcelain/cast iron caps and automatic ignition/re-ignition
- 24"W. thermostatically controlled steel griddle/simmer plate (separate burner/control for the left and right side)

#### 4GQ models include

- Four 15,000 BTU stainless steel burners with porcelain/cast iron caps and automatic ignition/re-ignition
- 12"W. thermostatically controlled steel griddle/simmer plate
- 12"W. grill with flavor generator plates and automatic ignition/re-ignition

### Model Options

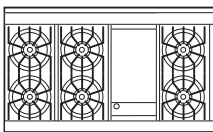

**VGIC486-6G\***  
Six-Burner/  
Griddle Range

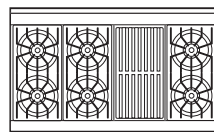

**VGIC486-6Q\***  
Six-Burner/  
Grill Range

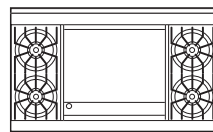

**VGIC486-4G\***  
Four-Burner/  
Double Griddle Range

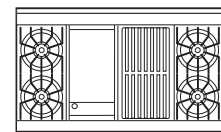

**VGIC486-4GQ\***  
Four-Burner/  
Griddle/Grill Range

#### FINISH DETAILS FOR ALL MODELS

- Stainless Steel (SS), Black (BK), White (WH), Metallic Silver (MS), Graphite Gray (GG), Stone Gray (SG), Taupe (TP), Biscuit (BT), Cotton White (CW), Oyster Gray (OG), Golden Mist (GM), Lemonade (LE), Sage (SA), Mint Julep (MJ), Sea Glass (SE), Iridescent Blue (IB), Viking Blue (VB), Pumpkin (PM), Racing Red (RR), Apple Red (AR), Burgundy (BU), Plum (PL), Chocolate (CH), and Cobalt Blue (CB).
  - Finish designates door front, lower front panel, and side panels.

- Has black porcelain grates, black porcelain burner caps, black porcelain grate supports/burner bowls, and black knobs/switches.
- White (WH)
  - Finish designates door front, lower front panel, side panels, porcelain grate supports/burner bowls, porcelain center worktop, and knobs/switches.
  - Has black porcelain grates and black porcelain burner caps.

- All finishes have stainless steel handle/chrome-plated brackets and stainless steel drip tray pull, control panel, and landing ledge.
- Brass Trim Option (BR)—nameplate, window trim, handle, drip tray pull, knob bezels, thermal-convection switch bezel, and grate support side trim. Brass components have a durable protective coating for maintenance-free normal use.

\*Shown throughout with 6"H. backguard. See **Installation Notes & Accessories** for details.

#### ORDERING INSTRUCTIONS

First specify model number, and then color code (VGIC486-6GSS). If ordering optional brass trim, specify code at end (VGIC486-6GSSBR). If ordering optional LP conversion, specify code at end (VGIC486-6GSSBRLP).





**Dimensions & Specifications**

**PRODUCT DIMENSIONS & DOOR SWING**



**VGIC486-6G**  
Six-Burner/  
Griddle Range

**VGIC486-6Q**  
Six-Burner/  
Grill Range

**VGIC486-4G**  
Four-Burner/  
Double Griddle Range

**VGIC486-4GQ**  
Four-Burner/  
Griddle/Grill Range

★ Please see **Installation Notes & Accessories** for important installation information including back-guard, high-shelf, island trim, and curb base front.



**Star-K Kosher Certification for use on the Jewish Sabbath or Jewish holidays**

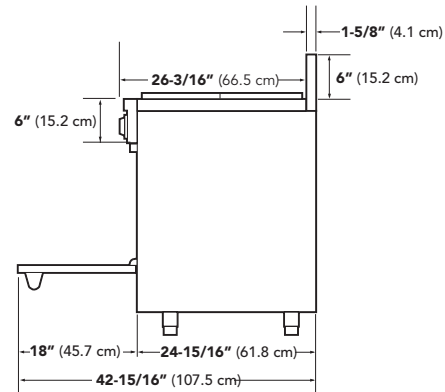
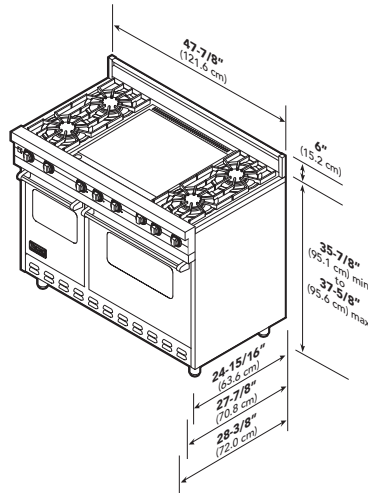

**All models**

Overall width	<b>47-7/8" (121.6 cm)</b>
Overall height	
Base height	
To top of grate support	<b>35-7/8" (91.1 cm) min. to 37-5/8" (95.6 cm) max.</b>
Legs adjust (with "spindles" fully extended)	<b>1-3/4" (4.5 cm)</b>
Additions to base height	
To top of grate	<b>Add 1-1/8" (2.9 cm)</b>
To top of island trim	<b>Add 1-1/4" (3.2 cm)</b>
To top of 6" backguard	<b>Add 6" (15.2 cm)</b>
To top of 10" backguard	<b>Add 10" (25.4 cm)</b>
To top of high-shelf	<b>Add 23-1/2" (59.7 cm)</b>
Overall depth (from rear)	
To end of side panel	<b>24-15/16" (63.3 cm)</b>
To end of control panels	<b>27-7/8" (70.8 cm)</b>
To end of knobs	<b>28-3/8" (72.0 cm)</b>
Oven	
Interior width	
Right	<b>23" (58.4 cm)</b>
Left	<b>12-1/8" (30.8 cm)</b>
Interior height	
Both	<b>16-1/8" (41.0 cm)</b>
Interior depth	
Right	<b>17" (43.2 cm)</b>
Left	<b>18-1/8" (45.9 cm)</b>
Overall interior size	
Right	<b>3.7 cu. ft.</b>
Left	<b>2.0 cu. ft.</b>





## Dimensions & Specifications

### CLEARANCE DIMENSIONS

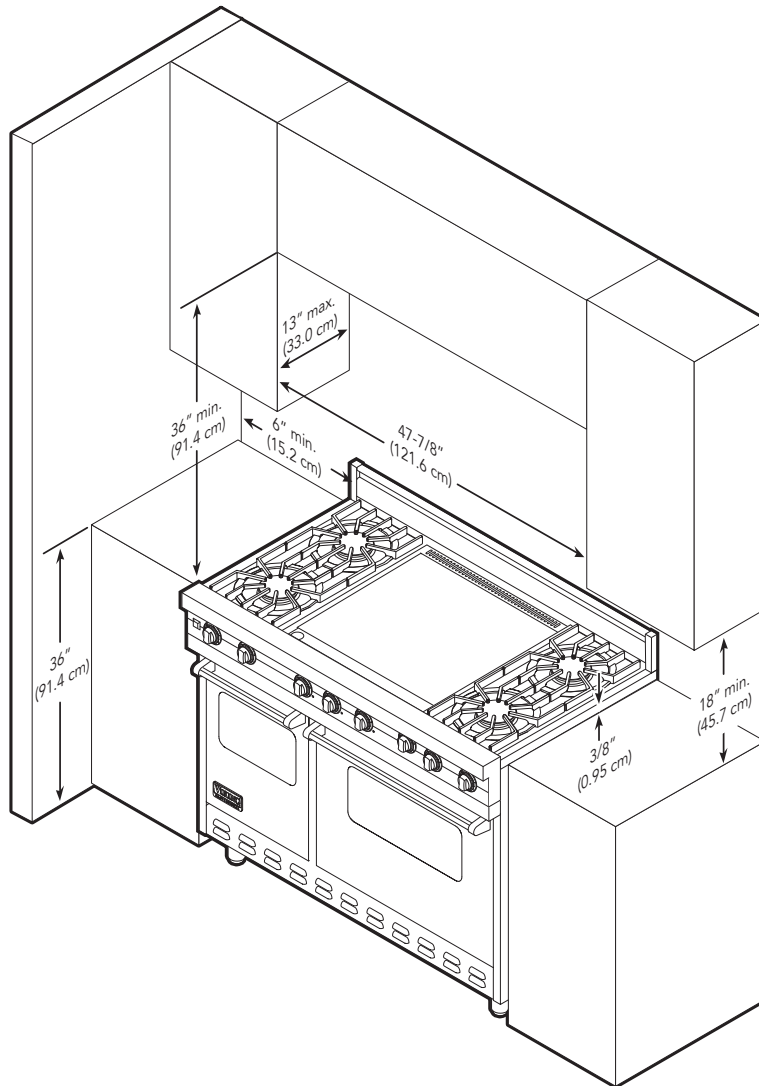

#### Minimum clearances from adjacent combustible construction

- Cooking surface and below, i.e., 36" (91.4 cm) and below
  - o Sides—0"
  - o Rear—0" with backguard or high-shelf; 0" with island trim and non-combustible rear wall; 6" (15.2 cm) with island trim and combustible rear wall
  - o Top grate support—36" (91.4 cm)
- Above cooking surface, i.e., above 36" (91.4 cm)
  - o Sides—6" (15.2 cm)
  - o Within 6" (15.2 cm) side clearance, wall cabinets no deeper than 13" (33.0 cm) must be minimum 18" (45.7 cm) above cooking surface
  - o Wall cabinets directly above product

must be minimum 36" (91.4 cm) for open top burners above cooking surface

- Use range only with factory supplied legs

1. This range may be installed directly adjacent to existing 36" (91.4 cm) high base cabinets. **Important** the top grate support **must** be 3/8" (0.95 cm) above the adjacent base cabinet countertop. This may be accomplished by raising the unit using the adjustment spindles on the legs.
2. The range **cannot** be installed directly adjacent to sidewalls, tall cabinets, tall appliances, or other side vertical surfaces above 36" (91.4 cm) high. There must be a minimum of 6" (15.2 cm)

side clearance from the range to such combustible surfaces above the 36" (91.4 cm) counter height.

3. Within the 6" (15.2 cm) side clearance to combustible vertical surfaces above 36" (91.4 cm), the maximum wall cabinet depth must be 13" (33.0 cm) and wall cabinets within this 6" (15.2 cm) side clearance must be 18" (45.7 cm) above the 36" (91.4 cm) high countertop.
4. Wall cabinets above the range must be a minimum of 36" (91.4 cm) above the range cooking surface for the full width of the range. This minimum height requirement does not apply if a range-hood is installed over the cooking surface.



**UTILITY REQUIREMENTS**



**GAS**

- Shipped natural gas standard; field convert to LP/propane with optional accessory kit or order as LP by adding LP after color code
- Accepts standard residential 1/2" ID gas service line
- Gas manifold pressure
  - o Natural gas 5.0" W.C.P.
  - o LP/Propane 10.0" W.C.P.



**ELECTRICAL**

- Four-foot (121.9 cm) cord included with range
- Three-wire with ground/three-prong plug
- 120 V/60 Hz
- Maximum amp usage—
  - o 6G—1.52
  - o 6Q—1.52
  - o 4G—1.89
  - o 4GQ—1.52



**PLUMBING**

Not applicable

**Installation Requirements**

**ACCESS REQUIREMENTS**



**VGIC486-6G**  
Six-Burner/  
Griddle Range

**VGIC486-6Q**  
Six-Burner/  
Grill Range

**VGIC486-4G**  
Four-Burner/  
Double Griddle Range

**VGIC486-4GQ**  
Four-Burner/  
Griddle/Grill Range

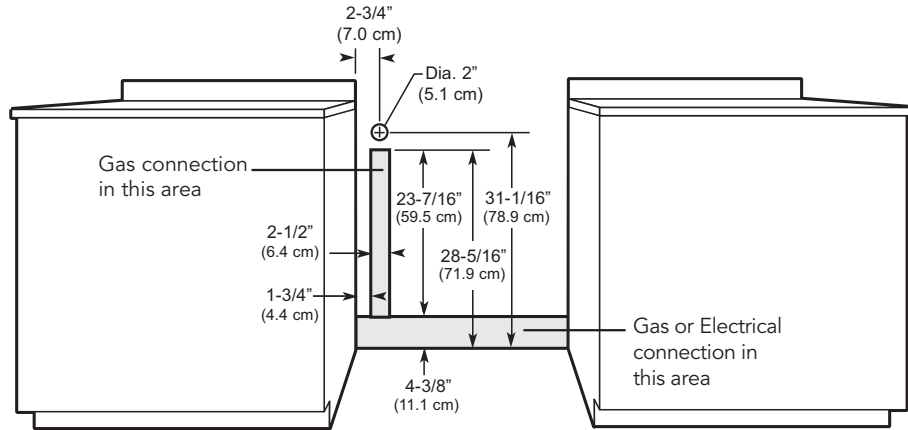

**Note:** Ground plug and electrical wire toward the direction of the electrical outlet.

	<b>VGIC486-6G</b>	<b>VGIC486-6Q</b>	<b>VGIC486-4G</b>	<b>VGIC486-4GQ</b>
Surface burner rating				
Six grated burners (each)	15,000 BTU Nat. (4.4 kW)/ 13,500 BTU LP (4.0 kW)	15,000 BTU Nat. (4.4 kW)/ 13,500 BTU LP (4.0 kW)		
Four grated burners (each)			15,000 BTU Nat. (4.4 kW)/ 13,500 BTU LP (4.0 kW)	15,000 BTU Nat. (4.4 kW)/ 13,500 BTU LP (4.0 kW)
Two griddles (each)			15,000 BTU Nat. (4.4 kW)/ 13,500 BTU LP (4.0 kW)	
One griddle	15,000 BTU Nat. (4.4 kW)/ 13,500 BTU LP (4.0 kW)			15,000 BTU Nat. (4.4 kW)/ 13,500 BTU LP (4.0 kW)
One grill		18,000 BTU Nat. (5.3 kW)/ 16,000 BTU LP (4.7 kW)		18,000 BTU Nat. (5.3 kW)/ 16,000 BTU LP (4.7 kW)
Broil burner rating				
Right oven only –		<b>18,000 BTU Nat. (5.3 kW)/16,000 BTU LP (4.7 kW)</b>		
Bake burner rating				
Right		<b>30,000 BTU Nat./LP (8.8 kW)</b>		
Left		<b>15,000 BTU Nat./LP (4.4 kW)</b>		





# COOKING

## Professional Freestanding Gas 48"W. Open Burner Range



### ✦ Installation & Notes & Accessories

A backguard, high-shelf, or island trim must be used for all installations.

#### 6"H. Backguard

- Stainless Steel (SS)
- Coordinates with all finishes

Model	Description	Approx. ship wt. lbs. (kg)
S48BG6	48"W. backguard	24 (10.8)

#### 10"H. Backguard

- Stainless Steel (SS)
- Coordinates with all finishes

Model	Description	Approx. ship wt. lbs. (kg)
S48BG10	48"W. backguard	27 (12.2)

#### High-shelf

- Stainless Steel (SS)
- Coordinates with all finishes
- Shelf comes attached to a 24"H. backguard

Model	Description	Approx. ship wt. lbs. (kg)
S4HS24	48"W. high-shelf	60 (27.0)

#### Island Trim

- Stainless Steel (SS)
- Coordinates with all finishes
- For island/peninsula installation
- Can replace backguard if wall is non-combustible

Model	Description	Approx. ship wt. lbs. (kg)
S48TII	48"W. island trim	15 (6.8)

#### Countertop Side Trim

- Stainless Steel (SS)
- Coordinates with all finishes
- One pair of trim
- Installs on side of unit; overlaps countertop

Model	Description	Approx. ship wt. lbs. (kg)
S24CST	24"D. side trim	2 (0.9)





### Installation Notes & Accessories

#### Curb Base Front

- Stainless Steel(SS)
- Coordinates with all finishes
- Front only
- Conceals range legs
- Completely assembled
- Easily clips onto range legs after range is installed

#### Custom Curb Base Front

- Remove stainless steel front and recycle
- Attach locally supplied trim
- Conceals range legs
- Completely assembled
- Easily clips onto range legs after range is installed
- Provides drop-in range look

Model	Description	Approx. ship wt. lbs. (kg)
RS48CBF4	48"W. curb base front	11 (5.0)

#### LP/Propane Conversion Kit

- Allows for field conversion of range from natural gas to LP

Model	Description	Approx. ship wt. lbs. (kg)
LPKPDR	Natural to LP/propane conversion kit	2 (0.9)

### Compliance Information



### WARRANTY INFORMATION\*

- One-year full warranty—complete product
- Ten-year limited warranty—porcelain oven and porcelain inner door panel
- Five-year limited warranty—surface burners, griddle burners, grill burners, and oven burner
- Ninety-day limited warranty—cosmetic parts such as glass, painted, and decorative items

\* For complete warranty see *Use & Care Guide*. Warranty valid on Viking products shipped within the United States and Canada.

