

Viking Installation Guide



Viking Range Corporation

111 Front Street

Greenwood, Mississippi 38930 USA

(662) 455-1200

For product information,

call 1-888-VIKING1 (845-4641)

or visit the Viking Web site at

vikingrange.com



(032508J)

Undercounter Trash Compactor

IMPORTANT - PLEASE READ AND FOLLOW

- Before beginning, please read these instructions completely and carefully.
- Do not remove permanently affixed labels, warnings, or plates from the product. This may void the warranty.
- Please observe all local and national codes and ordinances.
- Please ensure that this product is properly grounded.
- The installer should leave these instructions with the consumer who should retain for local inspector's use and for future reference.

BEFORE YOU START INSTALLATION

Proper installation is your responsibility. Make sure you have everything necessary for correct installation. It is the personal responsibility and obligation of the customer to contact a qualified installer to assure that electrical installation meets all local and national codes and ordinances.

Grounded electrical outlet is required. (See "Electrical Requirements")

Check the location where the compactor will be installed. Compactor is designed for recessed installation. Cabinet opening should be square. You should be able to fully open the compactor drawer. Allow 25" (63.5 cm) in front of compactor to remove drawer. Six inches of clearance is needed on the right side of the compactor drawer to be able to remove basket/bag.

WARNING: FIRE HAZARD
Do not let any item fall or collect behind the compactor. To do so may result in a fire.

FRONT

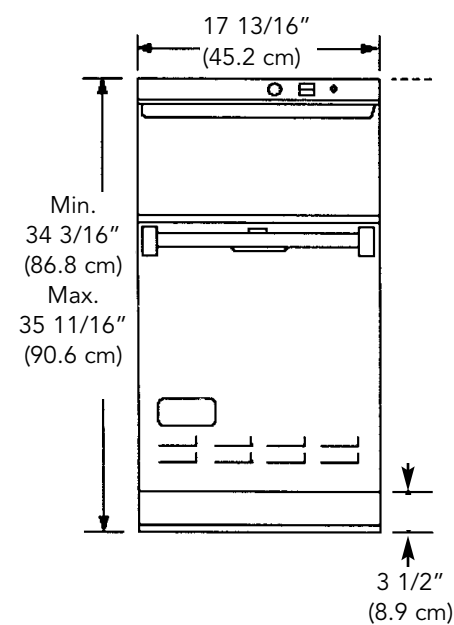

REAR

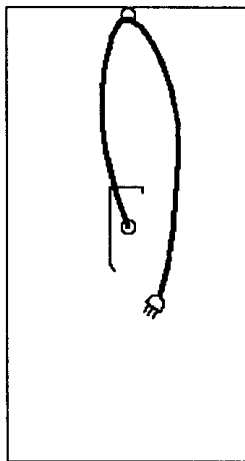

- Electric/Cord Data
- 2-wire with ground/ 3 prong plug
 - bracket to end - 54" (137.2 cm)
 - total length - 72" (182.9 cm)
 - 115 VAC/60 hz
 - separate 15 amp min.

SIDE

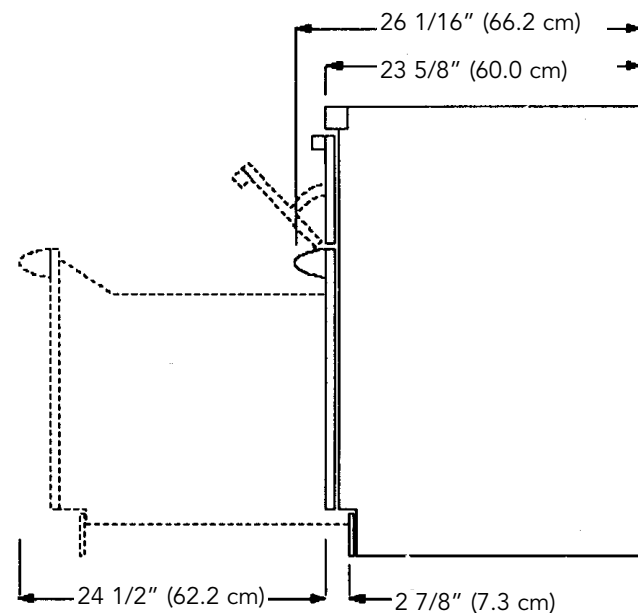

CUTOUT

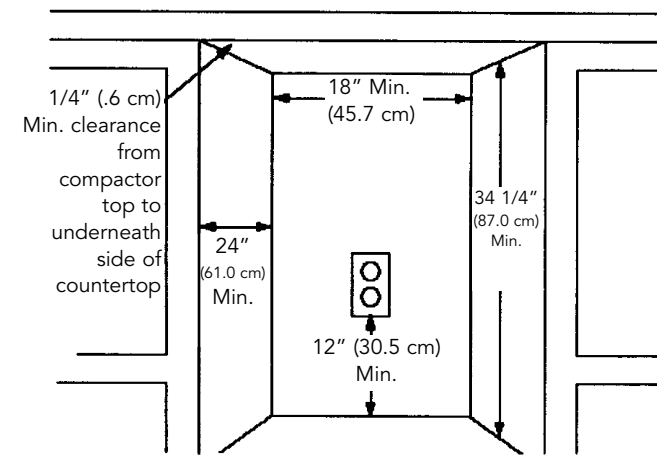

CLEARANCES

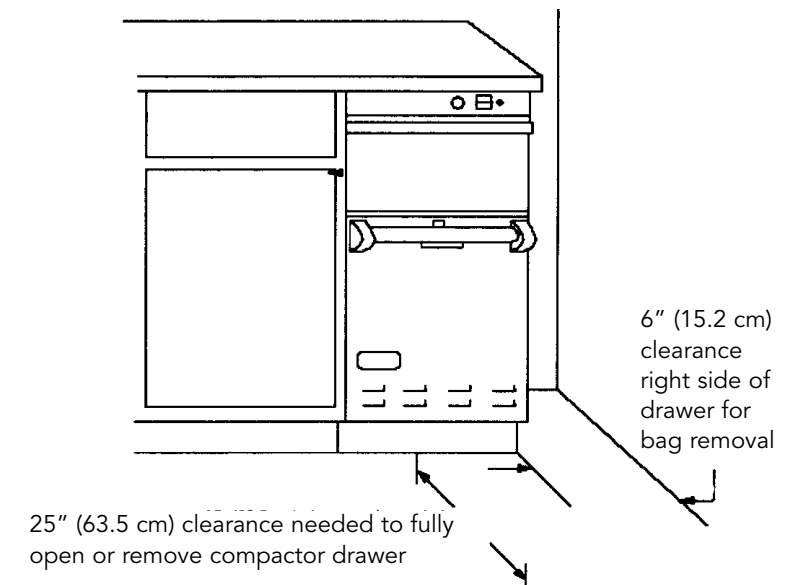

ELECTRICAL REQUIREMENTS

Important: Observe all governing codes and ordinances

WARNING: ELECTRICAL SHOCK HAZARD

- Electrical ground is required on this appliance.
- Improper connection of the equipment-grounding conductor can result in electric shock.
- Check with a qualified electrician if you are in doubt as to whether the appliance is properly grounded.
- Do Not modify the plug on the power supply cord. If it will not fit the outlet, have a proper outlet installed by a qualified electrician.
- Do Not use an extension cord with this appliance. Such use may result in a fire, electrical shock or other personal injury.
- Do Not have a fuse in the neutral or grounding circuit. A fuse in the neutral or grounding circuit could result in electrical shock.

Failure to follow these instructions could result in fire, electrical shock or other personal injury.

A 115 volt, 60 Hz fused electrical supply is required. (Time-delay fuse or circuit breaker is recommended). It is recommended that a separate circuit serving only this appliance be provided.

RECOMMENDED GROUNDING METHOD

Do Not, under any circumstances, remove the power supply cord grounding prong. For your personal safety, this appliance must be grounded. This appliance is equipped with a power supply cord having a 3-prong grounding plug. To minimize possible shock hazard, the cord must be plugged into a mating 3-prong, grounding type, wall receptacle, grounded in accordance with the National Electrical Code ANSI/NFPA 70 latest edition and all local codes and ordinances. If a mating wall receptacle is not available, it is the personal responsibility and obligation of the customer to have a properly grounded, 3-prong, wall receptacle installed by a qualified electrician.

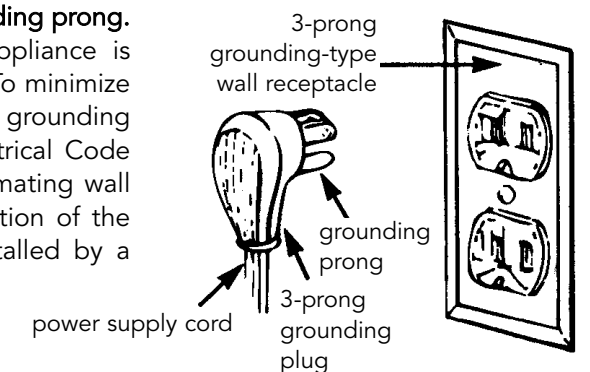

START INSTALLATION

Begin with compactor in room where it will be installed.

CAUTION: PRODUCT/FLOOR DAMAGE

- Do not grasp the console to move the compactor.
- Before moving compactor across floor, slide compactor onto cardboard or hardboard. Failure to follow these instructions may result in damage to floor covering or product.

1. Remove compactor from shipping carton. Remove all protective packaging materials such as tape and shipping pads. Waxy residue from protective shipping material may be removed with a mild solution of liquid household cleanser and water.
2. Check that power supply cord is attached to the cord bracket on the rear of the compactor.
3. Measure the height of the cabinet opening from the underside of the countertop to floor. Subtract 1/4" (.6 cm) from this measurement. Adjust compactor to this height using pliers to lower the compactor leveling feet away from the compactor.
4. Move compactor to final position. Turn key to STOP/LOCK position.
5. Place level on top of compactor. Check that compactor is level from front to back and side to side. Adjust the four leveling feet until compactor is level. Allow at least 1/4" (.6 cm) clearance between the compactor top and countertop.
6. Install anti-tip bracket.
7. Read use and care manual to fully understand your new compactor. Keep all literature in a safe place for future reference.

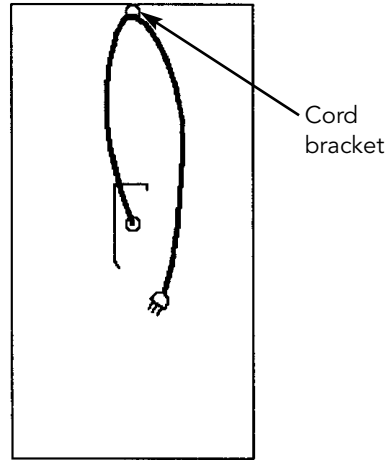

WARNING: PERSONAL INJURY HAZARD

When moving or lifting the compactor, use a glove to protect and cushion you hand. Failure to follow these instructions may result in personal injury.

CAUTION: FLOOR DAMAGE

Do not allow the rear frame of the compactor to touch the floor when lifting or rolling. Doing so could damage floor covering.

Installing the Anti-Tip Bracket:

1. After leveling legs, measure from the floor to the top of the compactor base plate from the backside. See Figure 1. This "A" measurement will determine the height needed for the bracket.
2. Measure from the floor to the bottom of the bracket with the measurement "A" + 1/8" (0.3 cm) and mark the two holes with a marker or pencil. Place the two screws into the bracket and tighten firmly to wall. See Figure 2. Note: Place the screws into a wall stud for better stability.
3. Plug power supply cord into grounded outlet. Move compactor into final position, making sure the bracket fits inside the opening in the rear of the unit.

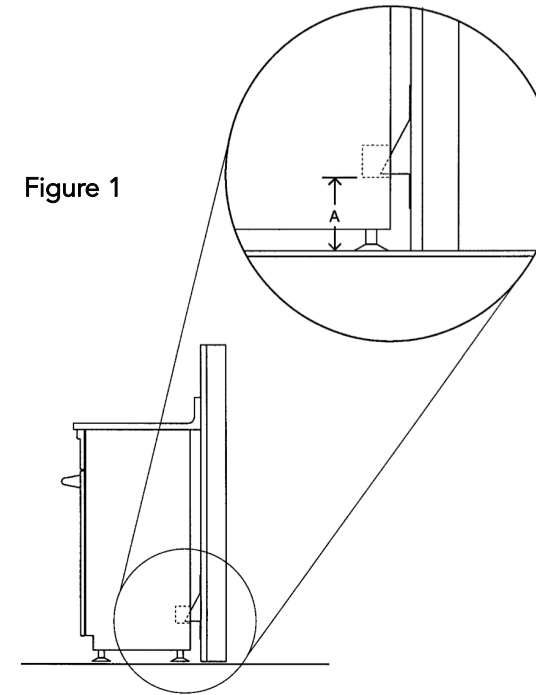

Figure 1

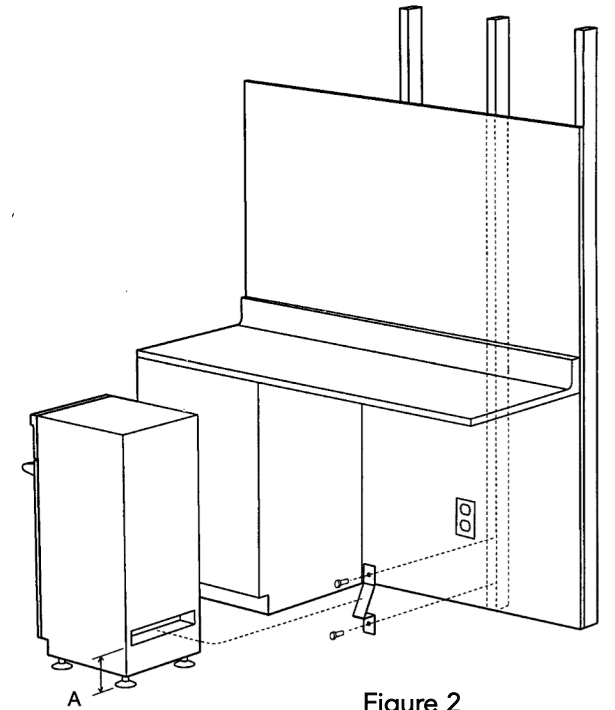

Figure 2

ADJUSTING TOE PLATE

If the toe plate rubs the floor covering, the toe plate clearance may be changed as follows:

1. Mark on each side of the toe plate the amount of toe plate that rubs the floor.
2. Fully open compactor drawer. Remove drawer retaining screws from track assembly on each side of drawer. Carefully remove the drawer from the track assembly. Place drawer on its back on top of two corner posts from carton.
3. With a ruler and a pencil or chalk, draw a line where the toe plate interferes with the floor covering.
4. Use a pair of scissors or a utility knife to cut toe plate along line.
5. Carefully slide drawer back into track assembly. Check the toe plate clearance. If toe plate still rubs floor covering, repeat steps 1-5.
6. When toe plate is adjusted properly, reattach drawer to track assembly with the two retaining screws.

