

Installation Guide

Viking Range, LLC
111 Front Street
Greenwood, Mississippi 38930 USA
(662) 455-1200

For product information,
call 1-888-845-4641
or visit our web site in the US at www.vikingrange.com
or in Canada at www.brigade.ca

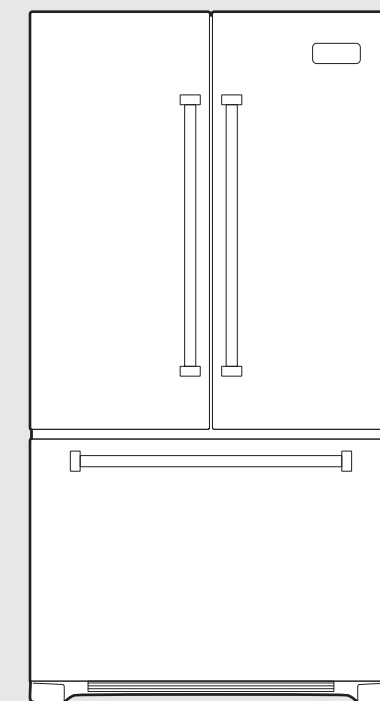

Counter-Depth
Freestanding French Door
Bottom-Mount Refrigerator/Freezer

Table of Contents

Warnings & Important Information	3
Proper Disposal	5
Dimensions (36" Bottom-Mount & French Door Bottom-Mount)	6
Specifications (36" Bottom-Mount & French Door Bottom-Mount)	7
Dimensions (36" French Door Bottom-Mount w/grille/side panels/top)	8
Specifications (36" French Door Bottom-Mount w/grille/side panels/top)	9
General Information	10
Remove the Packaging	10
Location Requirements	10
Moving Refrigerator	11
Electrical Requirements	11
Water Supply Requirements	12
Door & Drawer Remove	
Remove and Replace Handles	13
Remove Doors and Hinge	13
Replace Doors and Hinge	14
Remove and Replace Freezer Drawer	14
Replace Drawer Front	14
Installation	
Water Supply Requirements	15
Connect the Water Supply	15
Connect the Water Line	15
Leveling	17
Door Alignment	17
Complete Installation	18
Performance Checklist	18
Service & Registration	19

IMPORTANT— Please Read and Follow

It is the customer's responsibility to:

- Contact a qualified electrical installer.
- Read all instructions before using the refrigerator.
- Observe all local codes and ordinances. Install refrigerator according to installation instructions. All connections for water, electrical power and grounding must comply with local codes and be made by licensed personnel when required.
- **DO NOT** modify plug on power cord. If plug does not fit electrical outlet, have proper outlet installed by a qualified technician. Replace worn power cords and/or loose plugs.
- Assure that the electrical installation is adequate and in conformance with the National Electrical Code, ANSI/NFPA 70-latest edition or Canadian Electrical Code C22.1-1998 and C22.2 No. 0-M91 (or latest edition), and all local codes and ordinances. (115 volt, 60-Hz, 15 amp, fused, electrical supply is required. It is required that a separate circuit serving only this appliance be provided. This appliance is equipped with a power supply cord having a 3-prong grounding plug. To minimize possible shock hazard, the cord must be plugged into a mating 3-prong, grounding type wall receptacle. If a 2-prong receptacle is encountered, the customer must contact a qualified electrical installer to have it replaced with a properly grounded 3-prong receptacle. **DO NOT** use an extension cord or adapter plug.
- **DO NOT** ground to a gas line or cold-water pipe.
- **DO NOT** remove warning tag from power cord.
- Refrigerator is designed to operate on a separate 115 volt, 15 amp., 60 cycle line.
- **DO NOT** tamper with refrigerator controls.
- **DO NOT** service or replace any part of refrigerator unless specifically recommended in Use & Care or Installation Instructions. **DO NOT** attempt service if instructions are not understood or if they are beyond personal skill level.
- **ALWAYS** disconnect refrigerator from electrical supply before attempting to change light bulbs, clean, or service the refrigerator. Disconnect the power cord by grasping the plug, not the cord.
- **ALWAYS** read and follow manufacturer's storage and ideal environment instructions for items being stored in refrigerator.
- **DO NOT** allow children to operate, play with, crawl inside or stand on any part of the refrigerator.
- **DO NOT** clean refrigerator parts with flammable fluids. The fumes can create a fire hazard or explosion.
- Clean up spills or water leakage associated with water installation.
- Keep your refrigerator in good condition. Bumping or dropping refrigerator can damage refrigerator or cause refrigerator to malfunction or leak. If damage occurs, have refrigerator checked by qualified service technician.

Refrigerator Safety

Your safety and the safety of others are very important.

We have provided many important safety messages in this manual and on your appliance. Always read and obey all safety messages.



This is the safety alert symbol.

This symbol alerts you to potential hazards that can kill or hurt you and others.

All safety messages will follow the safety alert symbol and either the word "DANGER" or "WARNING."

These words mean:

⚠ DANGER

You can be killed or seriously injured if you don't immediately follow instructions.

⚠ WARNING

You can be killed or seriously injured if you don't follow instructions.

All safety messages will tell you what the potential hazard is, tell you how to reduce the chance of injury, and tell you what can happen if the instructions are not followed.

IMPORTANT SAFETY INSTRUCTIONS

WARNING: To reduce the risk of fire, electric shock, or injury when using your refrigerator, follow these basic precautions:

- Plug into a grounded 3 prong outlet.
- Do not remove ground prong.
- Do not use an adapter.
- Do not use an extension cord.
- Disconnect power before servicing.
- Replace all parts and panels before operating.
- Remove doors from your old refrigerator.
- Use nonflammable cleaner.
- Keep flammable materials and vapors, such as gasoline, away from refrigerator
- Use two or more people to move and install refrigerator.
- Disconnect power before installing ice maker (on ice maker kit ready models only).
- Use a sturdy glass when dispensing ice (on some models).

SAVE THESE INSTRUCTIONS

⚠ WARNING

State of California Proposition 65 Warning

- This product contains one or more chemicals known to the State of California to cause cancer.
- This product contains one or more chemicals known to the State of California to cause birth defects or other reproductive harm.

IMPORTANT— Please Read and Follow

A GFI shall be used if required by NFPA-70 (National Electric Code), federal/state/local laws, or local ordinances.

- The required use of a GFI is normally related to the location of a receptacle with respect to any significant sources of water or moisture.
- Viking Range Corporation will **NOT** warranty any problems resulting from GFI outlets which are not installed properly or do not meet the requirements below.

If the use of a GFI is required, it should be:

- Of the receptacle type (breaker type or portable type **NOT** recommended)
- Used with permanent wiring only (temporary or portable wiring **NOT** recommended)
- On a dedicated circuit (no other receptacles, switches or loads in the circuit)
- Connected to a standard breaker of appropriate size (GFI breaker of the same size **NOT** recommended)
- Rated for Class A (5 mA +/- 1 mA trip current) as per UL 943 standard)
- In good condition and free from any loose-fitting gaskets (if applicable in outdoor situations)
- Sheltered from moisture (water, steam, high humidity) as much as reasonably possible

Proper Disposal (of old refrigerator)

IMPORTANT:

Child entrapment and suffocation are not problems of the past. Junked or abandoned refrigerators are still dangerous - even if they will sit for "just a few days." If you are getting rid of your old refrigerator, please follow these instructions to help avoid accidents.

Before You Throw Away Your Old Refrigerator or Freezer:

- Take off the doors.
- Leave the shelves in place so that children may not easily climb inside.

⚠ WARNING

Suffocation Hazard

Remove doors from your old refrigerator.

Failure to do so can result in death or brain damage.

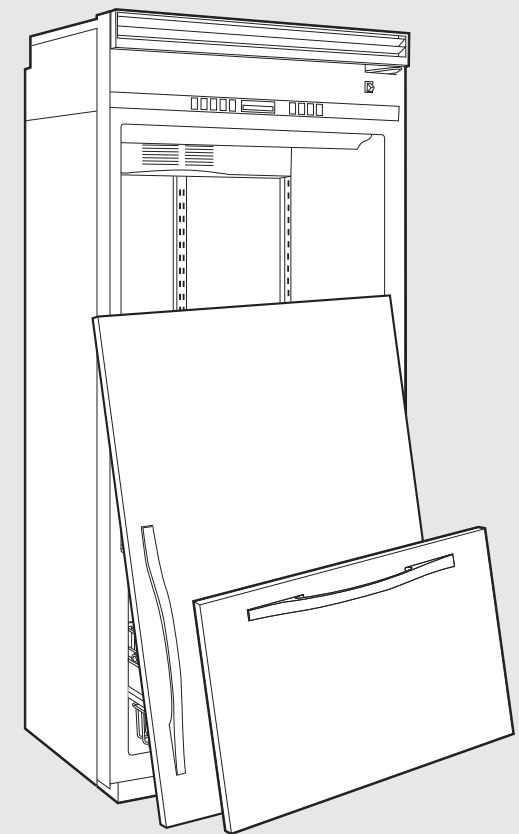

Dimensions (Professional)

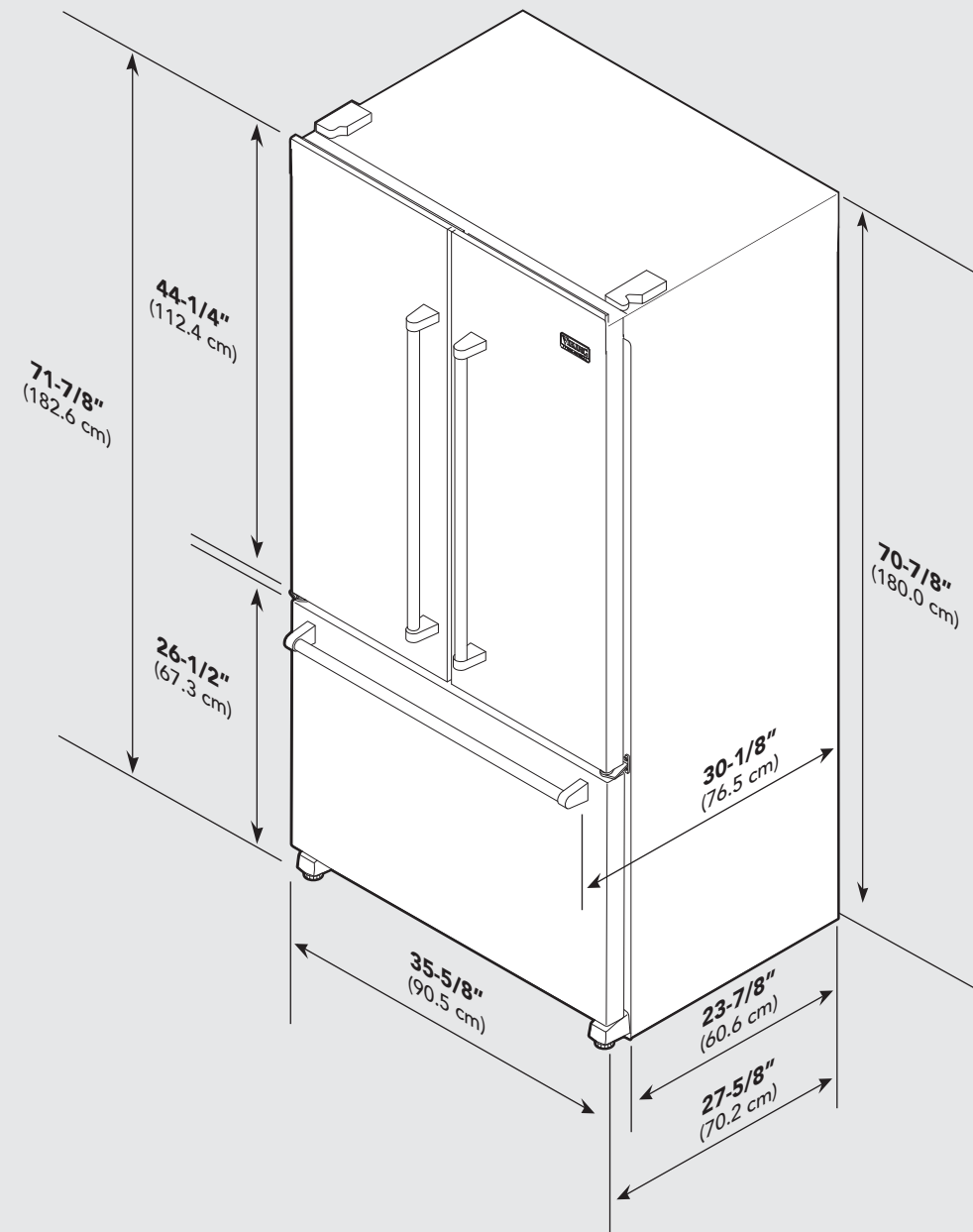

Specifications

French Door Bottom-Mount	
Description	VCFE236
Overall width	35-5/8" (90.5 cm)
Overall height	To top of door: 71-7/8" (182.6 cm) To top of cabinet: 70-7/8" (180.0 cm)
Overall depth from rear	To front edge of cabinet: 23-7/8" (60.6 cm) To front of door: 27-5/8" (70.2 cm) To front of handle endcap: 30-1/8" (76.5 cm)
Cutout height	Back of refrigerator - 71-3/8" (181.3 cm) Front of refrigerator - 72-3/8" (183.8 cm)
Cutout width	36" (91.4 cm)
Cutout depth	24-1/2" (62.2 cm)
Electrical requirements	115 volt, 60 Hz, 15 amp dedicated circuit; 3-wire cord with grounded 3-prong plug attached to product
Maximum amp usage	7.1 amps
Inlet water requirements	1/4" copper tubing inlet waterline; minimum 35 psi; maximum 120 psi
Overall interior capacities	
Refrigerator	16.3 cu. ft. (461.6 liters)
Freezer	5.5 cu. ft. (155.7 liters)
Total capacity	21.8 cu. ft. (617.3 liters)
Approximate shipping weight	355 lbs. (160 kg)

Dimensions (with Grille/Side Panels/Top)

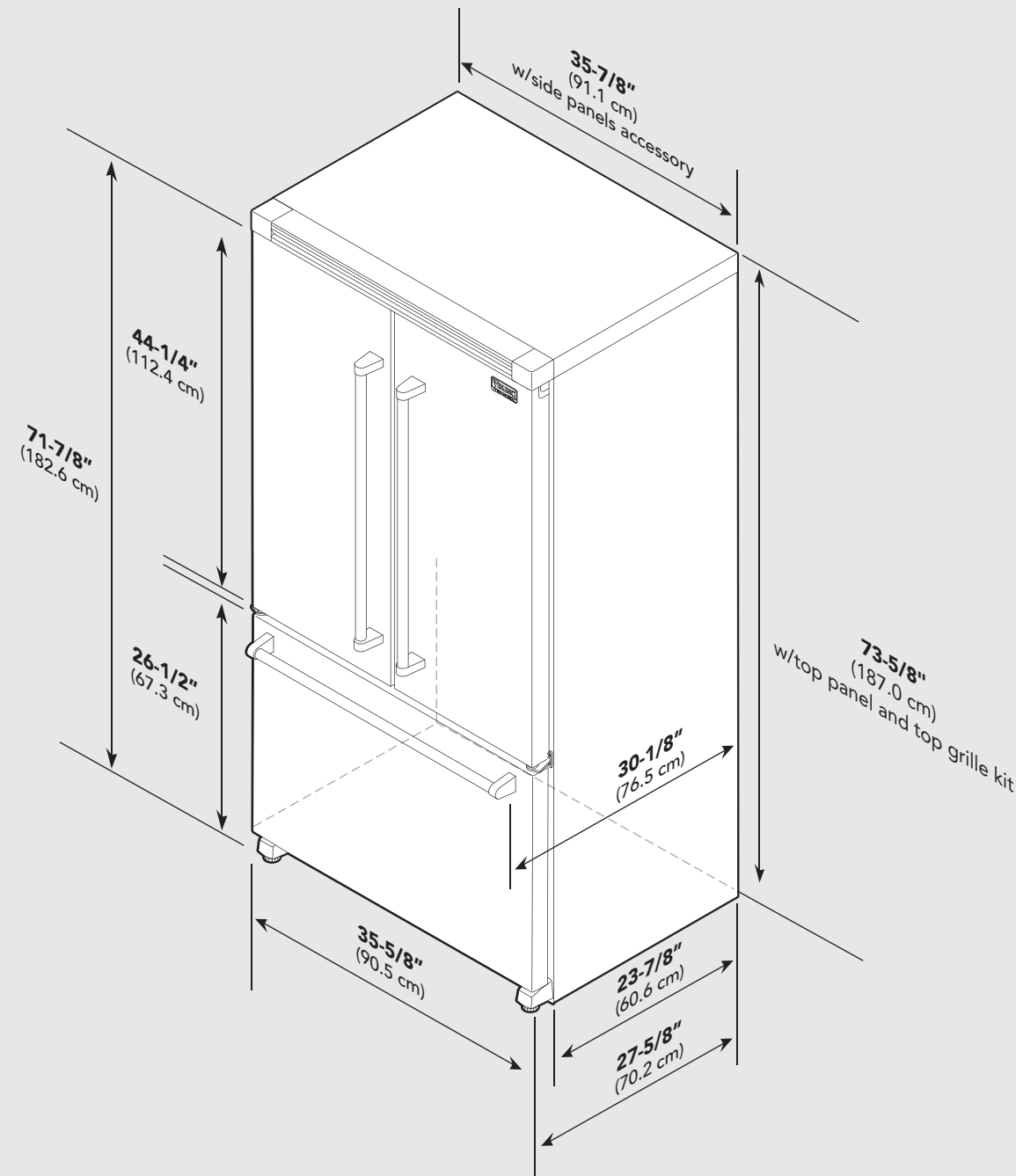

Specifications (with Grille/Side Panels/Top)

French Door Bottom-Mount	
Description	VCFF236 with Top, Top Grille Kit & Side Panels
Overall width	Addition of side panel: 35-7/8" (91.1 cm)
Overall height	To top of cabinet with addition to top kit: 73-5/8" (187.0 cm)
Overall depth from rear	To front edge of cabinet: 23-7/8" (60.6 cm) To front of door: 27-5/8" (70.2 cm) To front of handle endcap: 30-1/8" (76.5 cm)
Cutout height	Addition of top grilles/top kit: 73-3/4" (187.3 cm)
Cutout width	36" (91.4 cm)
Cutout depth	24-1/2" (62.2 cm)
Electrical requirements	115 volt, 60 Hz, 15 amp dedicated circuit; 3-wire cord with grounded 3-prong plug attached to product
Maximum amp usage	7.1 amps
Inlet water requirements	1/4" copper tubing inlet waterline; minimum 35 psi; maximum 120 psi
Overall interior capacities	
Refrigerator	16.3 cu. ft. (461.6 liters)
Freezer	5.5 cu. ft. (155.7 liters)
Total capacity	21.8 cu. ft. (617.3 liters)
Approximate shipping weight	355 lbs. (160 kg)

General Information

Your refrigerator was packed carefully for shipment. Remove and discard all packaging and tape. **DO NOT** remove the model/serial number label.

⚠️ WARNING

Excessive Weight Hazard

Use two or more people to move and install refrigerator.

Failure to do so can result in back or other injury.

Remove the Packaging

- Remove tape and glue residue from surfaces before turning on the refrigerator. Rub a small amount of liquid dish soap over the adhesive with your fingers. Wipe with warm water and dry.
- DO NOT** use sharp instruments, rubbing alcohol, flammable fluids, or abrasive cleaners to remove tape or glue. These products can damage the surface of your refrigerator. For more information, see "Refrigerator Safety."
- Dispose of/recycle all packaging materials.

When moving your refrigerator:

Your refrigerator is heavy. When moving the refrigerator for cleaning or service, be sure to protect the floor. Always pull the refrigerator straight out when moving it. **DO NOT** wiggle or "walk" the refrigerator when trying to move, as floor damage could occur.

Clean Before Using

After you remove all of the packaging materials, clean the inside of your refrigerator before using it. See the cleaning instructions in "Use and Care Guide."

Important information to know about glass shelves and covers:

DO NOT clean glass shelves or covers with warm water when they are cold. Shelves and covers may break if exposed to sudden temperature changes or impact, such as bumping. For your protection, tempered glass is designed to shatter into many small, pebble-size pieces. This is normal. Glass shelves and covers are heavy. Use special care when removing them to avoid impact from dropping.

⚠️ WARNING



Explosion Hazard

Keep flammable materials and vapors, such as gasoline, away from refrigerator.

Failure to do so can result in death, explosion, or fire.

Location Requirements

- DO NOT** install refrigerator near oven, radiator or other heat sources. If not possible, shield refrigerator material.
- DO NOT** install where the temperature falls below 55°F (13°C) or rises above 110°F (43°C). Malfunctions can occur at these temperatures.
- Refrigerator is designed for indoor household application only.

General Information

To ensure proper ventilation for your refrigerator, allow for a 1/2" (1.25 cm) space on each side and at the top. Allow 1/2" (1.3 cm) of space behind the refrigerator. If your refrigerator has an ice maker, allow extra space at the back for the water line connections. When installing your refrigerator next to a fixed wall, leave a 2-3/4" (7.0 cm) minimum space between the refrigerator and wall to allow the door to swing open.

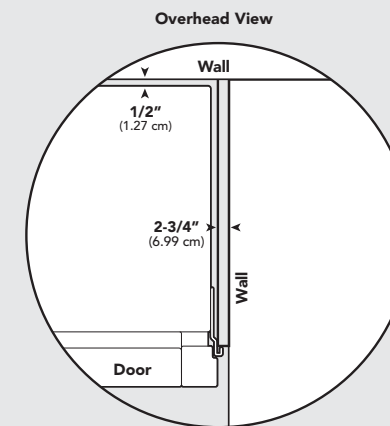

Moving Unit

- DO NOT** transport the refrigerator on its side. If an upright position is not possible, lay the refrigerator on its back. Allow refrigerator to sit upright for approximately 30 minutes before plugging it in to assure oil returns to the compressor. Plugging the refrigerator in immediately may cause damage to internal parts.
- Use an appliance dolly when moving refrigerator. **ALWAYS** truck refrigerator from its side or back - **NOT** from its front.
- Cover outside finish of refrigerator during transport by wrapping cabinet in blankets or inserting padding between the refrigerator and dolly.
- Secure refrigerator to dolly firmly with straps or bungee cords. Thread straps through handles when possible. **DO NOT** overtighten. Overtightening restraints may dent or damage outside finish.

Electrical Requirements

⚠️ WARNING



Electrical Shock Hazard

Plug into a grounded 3 prong outlet.

Do not remove ground prong.

Do not use an adapter.

Do not use an extension cord.

Failure to follow these instructions can result in death, fire, or electrical shock.

Before you move your refrigerator to its final location, it is important to make sure you have the proper electrical connection.

Recommended Grounding Method

A 115 Volt, 60 Hz., AC only 15- or 20-amp fused, grounded electrical supply is required. It is recommended that a separate circuit serving only your refrigerator be provided. Use an outlet that cannot be turned off by a switch. **DO NOT** use an extension cord.

Note: Before performing any type of installation, cleaning, or removing a light bulb, turn the cooling **OFF**. Disconnect the refrigerator from the electrical source. When you are finished, reconnect the refrigerator to the electrical source and turn cooling on.

General Information

Water Supply Requirements

A cold water supply with water pressure of between 35 and 120 psi (241 and 827 kPa) is required to operate the water dispenser and ice maker. If you have questions about your water pressure, call a licensed, qualified plumber.

Reverse Osmosis Water Supply

IMPORTANT: The pressure of the water supply coming out of a reverse osmosis system going to the water inlet valve of the refrigerator needs to be between 35 and 120 psi (241 and 827 kPa).

If a reverse osmosis water filtration system is connected to your cold water supply, the water pressure to the reverse osmosis system needs to be a minimum of 40 to 60 psi (276 to 414 kPa).

If the water pressure to the reverse osmosis system is less than 40 to 60 psi (276 to 414 kPa):

- Check to see whether the sediment filter in the reverse osmosis system is blocked. Replace the filter if necessary.
- Allow the storage tank on the reverse osmosis system to refill after heavy usage.
- If your refrigerator has a water filter, it may further reduce the water pressure when used in conjunction with a reverse osmosis system. Remove the water filter.

If you have questions about your water pressure, call a licensed, qualified plumber.

Doors & Drawer Removal

Remove and Replace Handles

1. Using a 3/32" or 1/8" hex wrench, loosen the two set screws located on the side of each handle.
2. Pull the handle straight out from the door. Make sure you keep the screws for reattaching the handles.
3. To replace the handles, reverse the directions.

Remove Doors and Hinges

IMPORTANT: Remove food and any adjustable door or utility bins from doors.

TOOLS NEEDED: 5/16", 3/8", 1/4" hex-head socket wrench, #2 Phillips screwdriver, and a flat-blade screwdriver.

1. Unplug refrigerator or disconnect power.
2. Keep the refrigerator doors closed until you are ready to lift them free from the cabinet.

Note: Provide additional support for the refrigerator door while the hinges are being removed. **DO NOT** depend on the door gasket magnets to hold the door in place while you are working.

3. Starting with the right-hand side door, remove the parts for the top hinge as shown in Top Hinge graphic. Lift the refrigerator door from the bottom hinge pin.

Note: Remove the hinge pin cover from the bottom hinge pin and keep for later use. See Bottom Hinge graphic.

4. Before removing the left-hand side door, disconnect the wiring plug located on the top of the top hinge by wedging a flat-blade screwdriver or fingernail between the two sections. See Wiring Plug graphic.

Remove Doors and Hinges (cont.)

6. Remove the parts for the top hinge as shown in Top Hinge graphic. Lift the left-hand side door from the bottom hinge pin.

Note: Remove the hinge pin cover from the bottom hinge pin and keep it for later use. See Bottom Hinge graphic.

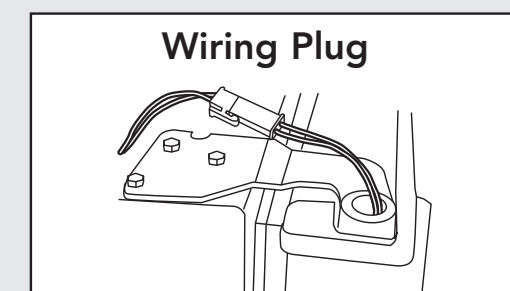
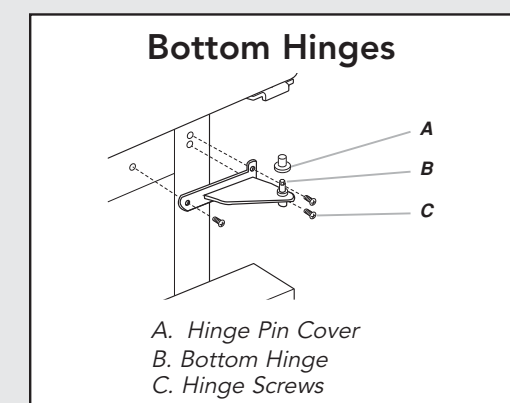
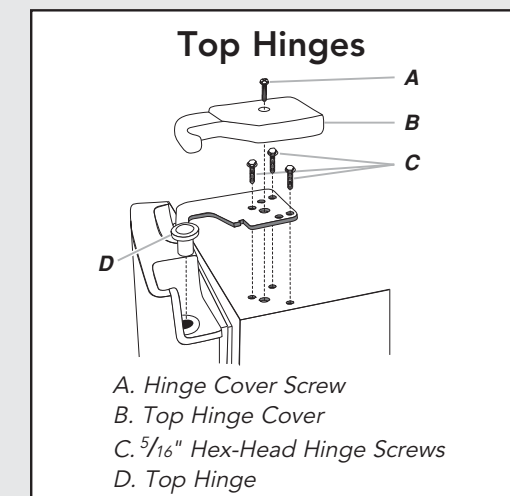

Door & Drawer Removal (cont.)

Replace Doors and Hinges

1. Assemble the parts for the top hinge as shown in Top Hinge graphic. **DO NOT** tighten the screws completely.
2. Replace the parts for the bottom hinge as shown in Bottom Hinge graphic. Tighten screws. Replace the refrigerator door.

Note: Provide additional support for the refrigerator door while the hinges are being moved. **DO NOT** depend on the door gasket magnets to hold the door in place while you are working.
3. Align the door so that the bottom of the refrigerator door aligns evenly with the top of the freezer drawer. Tighten all screws.
4. Reconnect the wiring plug on top of the left-hand side refrigerator door.
5. Replace the top hinge covers.

Remove and Replace Freezer Drawer

IMPORTANT: Two people may be required to remove and replace the freezer drawer.

Remove Drawer Front

1. Open the freezer drawer to full extension.
2. Loosen the four screws attaching the drawer glides to the drawer front. See *Drawer Front Removal* graphic.

Note: Loosen screws three to four turns. Keep the screws in the drawer front.
3. Lift drawer front upward and off the screws. See *Drawer Front Removal* graphic.

Replace Drawer Front

1. Slide the drawer glides out of the freezer compartment. Insert the screws in the top of the drawer front into the slots in the drawer brackets. See *Drawer Front Replacement* graphic.
2. Pull the drawer brackets toward you to position the two screws in the bottom of the drawer front into the brackets. See *Drawer Front Replacement* graphic.
3. Completely tighten the four screws.

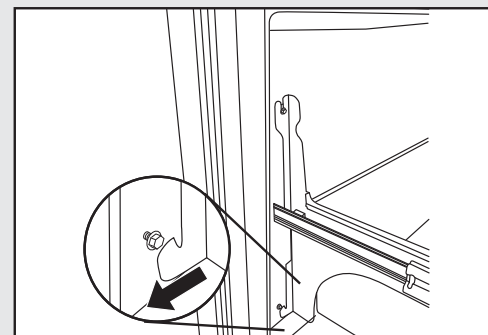
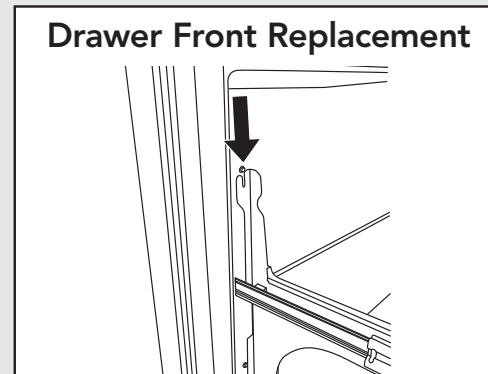
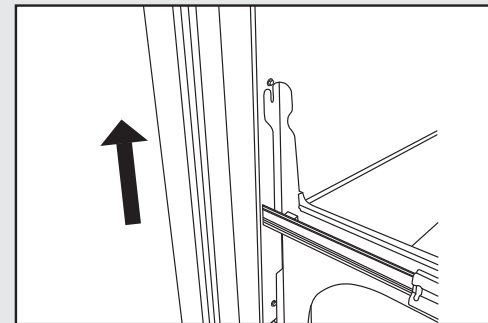
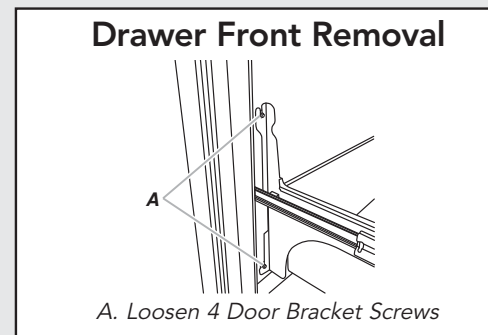

Installation

Water Supply Requirements

Gather the required tools and parts before starting installation. Read and follow the instructions provided with any tools listed here.

TOOLS NEEDED:

- Flat-blade screwdriver
- 7/16" and 1/2" Open-end or two adjustable wrenches
- 1/4" Nut driver
- 1/4" Drill bit
- Cordless drill

IMPORTANT:

- All installations must meet local plumbing code requirements.
- **DO NOT** use a piercing-type or 3/16" (4.76 mm) saddle valve which reduces water flow and clogs more easily.
- Use copper tubing and check for leaks. Install copper tubing only in areas where the household temperatures will remain above freezing.

Connect the Water Supply

IMPORTANT: If you turn the refrigerator on before the water line is connected, turn the ice maker **OFF**.

Connect to Water Line

1. Unplug refrigerator or disconnect power.
2. Turn **OFF** main water supply. Turn **ON** nearest faucet long enough to clear line of water.
3. Locate a 1/2" to 1-1/4" (12.7 mm to 31.8 mm) vertical cold water pipe near the refrigerator.

IMPORTANT:

- Make sure it is a cold water pipe.
- Horizontal pipe will work, but drill on the top side of the pipe, not the bottom. This will help keep water away from the drill and normal sediment from collecting in the valve.

4. Determine the length of copper tubing you need. Measure from the connection on the rear of the refrigerator to the water pipe. Add 7 ft (2.1 m) to allow for cleaning. Use 1/4" (6.35 mm) O.D. (outside diameter) copper tubing. Be sure both ends of copper tubing are cut square.
5. Using a cordless drill, drill a 1/4" hole in the cold water pipe you have selected.

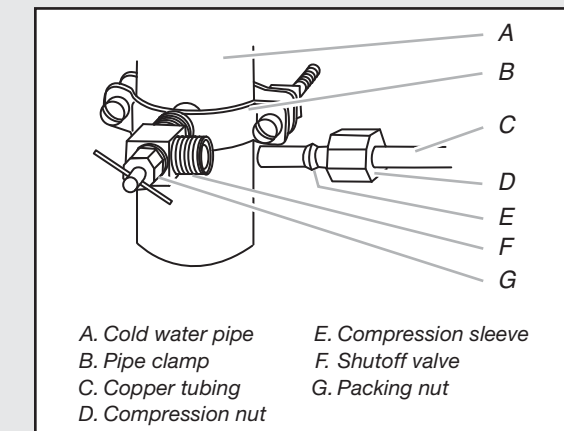

Installation

Connect to Water Line (cont.)

- Fasten the shutoff valve to the cold water pipe with the pipe clamp. Be sure the outlet end is solidly in the 1/4" drilled hole in the water pipe and that the washer is under the pipe clamp. Tighten the packing nut. Tighten the pipe clamp screws slowly and evenly so washer makes a watertight seal. **DO NOT** overtighten or you may crush the copper tubing.
- Slip the compression sleeve and compression nut on the copper tubing as shown. Insert the end of the tubing into the outlet end squarely as far as it will go. Screw compression nut onto outlet end with adjustable wrench. **DO NOT** overtighten.
- Place the free end of the tubing in a container or sink, and turn **ON** the main water supply. Flush the tubing until water is clear. Turn **OFF** the shutoff valve on the water pipe.

- Using an adjustable wrench, hold the nut on the plastic water line to keep it from moving. Then, with a second wrench, turn the compression nut on the copper tubing counterclockwise to completely tighten. **DO NOT** overtighten.

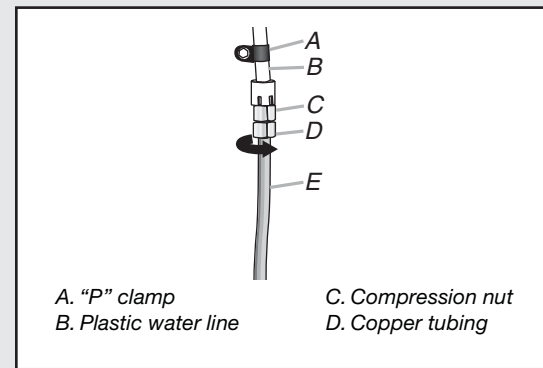

Connect to Refrigerator

- Create a service loop (minimum diameter of 2 ft. [61.0 cm]) with the copper tubing. Avoid kinks when coiling the copper tubing.
- Remove the plastic cap from water valve inlet port. Place a compression nut and sleeve on the copper tubing.
- Insert the end of the copper tubing into the water valve inlet port. Shape tubing slightly so that the tubing feeds straight into the port to avoid kinks.
- Slide the compression nut over the sleeve and screw into the water valve inlet port.

- Check connection by pulling on copper tubing. Attach copper tubing to refrigerator cabinet with a "P" clamp. Turn on water supply to refrigerator and check for leaks. Correct any leaks.

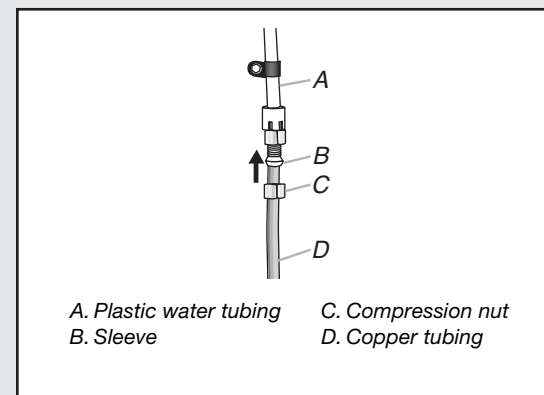

Leveling/Adjusting the Door

To enhance the appearance and maintain performance, the refrigerator should be level. To protect property and refrigerator from damage, observe the following:

- Protect vinyl or other flooring with cardboard, rugs, or other protective material.
- DO NOT** use power tools when performing leveling procedure.

Materials Needed

- 1/4" hex head driver
- Carpenter's level

Note: Complete any required panel installation and/or water supply connection before leveling. Refrigerator should be in permanent location prior to leveling.

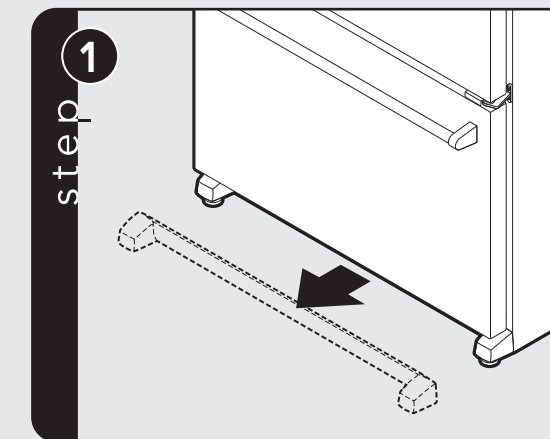

Remove toe grille. Grasp firmly and pull outward to unclip.

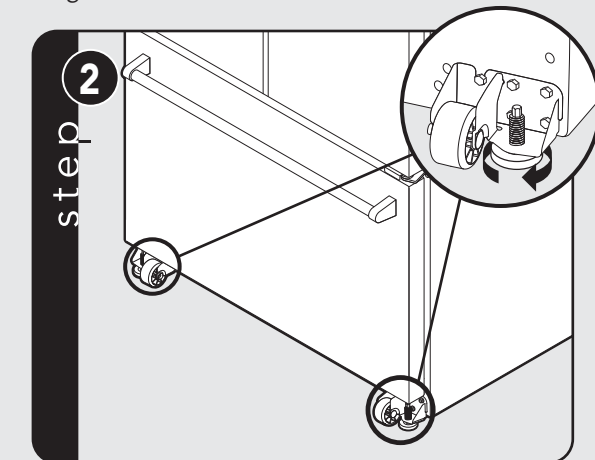

To raise the front of the refrigerator, turn the leveler foot screw clockwise. **Note:** Having someone push against the top of the refrigerator takes some weight off the leveler foot screws.

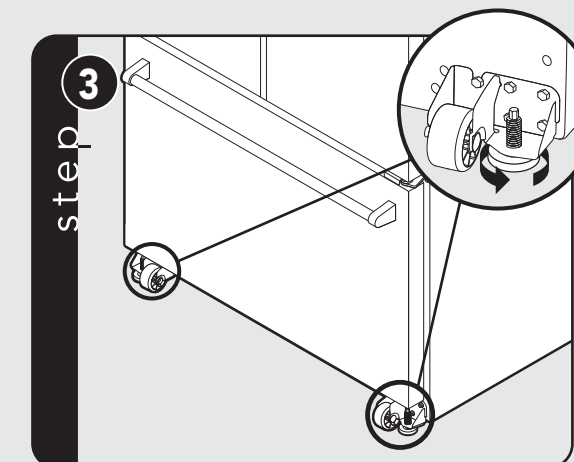

To lower the front of the refrigerator, turn the leveler foot screw counterclockwise. **Note:** Having someone push against the top of the refrigerator takes some weight off the leveler foot. It may take several turns of the leveler foot screw to adjust the tilt of the refrigerator.

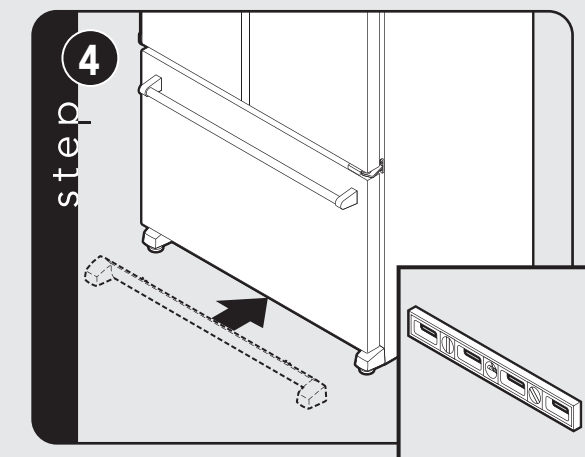

Replace toe grille. Align the toe grille mounting clips with the lower cabinet slots. Push the toe grille firmly until it snaps into place. Check for level.

Complete the Installation

Final Steps

1. Plug into a grounded 3 prong outlet.
2. Return all removable parts to doors and drawer and food to refrigerator and freezer.

Note: Allow 24 hours to produce the first batch of ice. Discard the first three batches of ice produced. Allow three days to completely fill the ice container.

⚠ WARNING



Electrical Shock Hazard

Plug into a grounded 3 prong outlet.

Do not remove ground prong.

Do not use an adapter.

Do not use an extension cord.

Failure to follow these instructions can result in death, fire, or electrical shock.

Performance Checklist

- Plug-in refrigerator and verify operation.
- Connect water supply (if applicable).
 - Verify icemaker bail arm is down.
 - Verify dispenser operation (if applicable).
- Align/square door(s).
- Verify drain pan properly installed and no leaks on water connection.
- Remove internal packaging and labels and wipe refrigerator down.

Installer's information:

Installer's name: _____

Installer's company: _____

Date: _____

Service & Registration

Only authorized replacement parts may be used in performing service on the appliance. All servicing should be referred to a qualified technician.

Contact Viking Range, LLC, 1-888-845-4641, for the nearest service parts distributor in your area or write to:

**VIKING RANGE, LLC
PREFERRED SERVICE
111 Front Street
Greenwood, Mississippi 38930 USA**

The serial and model numbers for your refrigerator are located on the upper wall, behind the lighting.

Record the following information indicated below. You will need it if service is ever required.

Model number _____

Serial number _____

Date of purchase _____

Date installed _____

Dealer's name _____

Address _____

These installation instructions should remain with the refrigerator for future reference.