



BUILT-IN 5 SERIES ELECTRIC COOKTOPS

Viking 5 Series – VECU

COMMERCIAL-TYPE COOKING POWER

- *QuickCook™ Surface Infrared Elements* with ribbon technology reach full power in three seconds and provide fast cooking with nearly all cookware
- *Up to 10 cooking zones*, including a 12"– 3,200 watt triple element, provide space and power options for most cookware
- Bridge element connects front and rear elements to create a continuous heated surface for oversized cookware or optional griddle accessory
- Infrared energy transfer provides fast cooking, regardless of type of cookware used cooking

ELECTRIC 30" WIDE COOKTOP

- Left front (triple element) – 12" 3,200-watt element
- Left rear – 6 1/2", 1,200-watt element
- Bridge – 800 watt
- Right front – 8 1/2", 1,800-watt element
- Right rear – 8 1/2", 1,800-watt element

ELECTRIC 36" WIDE COOKTOP

- Left front (triple element) – 12" 3,200-watt element
- Left rear – 6 1/2", 1,200-watt element
- Center front – 8 1/2", 1,800-watt element
- Bridge – 800-watt
- Center rear – 8 1/2", 1,800-watt element
- Right front – 6 1/2", 1,200-watt element
- Right rear (dual element) – 8 1/2", 2,000-watt element

EASY MAINTENANCE AND CLEANUP

- Durable, wear-resistant glass ceramic surface and laser-etched graphics withstand the rigors of regular cleaning
- Removable knobs for quick, simple cleaning



SAFE-EASY OPERATION

- **NEW** BlackChrome™ Knobs
- Child proof, push-to-turn metal knobs for safe use
- Element lights indicate hot surfaces and active elements

MODEL NUMBERS

- VECU53014BSB – 30"W. Electric Cooktop; four burners
- VECU53616BSB – 36"W. Electric Cooktop; six burners

ACCESSORIES

- PGDVEC – Portable non-stick cast aluminum griddle fits over bridge and elements for griddling or defrosting food

COLOR FINISHES

- Available in Stainless Steel/
Black Glass (SB)

WARRANTY

- 2-year full - complete product
- 90-day full - cosmetic parts such as glass, painted items and decorative items
- 5-year limited - electric element components



BUILT-IN 5 SERIES ELECTRIC COOKTOPS

Viking 5 Series – VECU

ELECTRIC COOKTOPS		
DESCRIPTION	VECU53014B	VECU53616B
Overall Width	30-3/4" (78.1 cm)	36-3/4" (93.3 cm)
Overall Height from bottom To top of knobs To top of cooking surface To bottom edge of frame		6-1/8" (15.6 cm) 4-7/8" (12.4 cm) 4" (10.2 cm)
Overall Depth from rear	21" (53.3 cm)	
Cutout Width	28-7/8" (73.3 cm) minimum to 29-1/8" (74.0 cm) maximum	34-7/8" (88.6 cm) minimum to 35-1/8" (89.2 cm) maximum
Cutout Depth	19-1/4" (48.9 cm) minimum to 19-3/4" (50.2 cm) maximum	
Electrical Requirements	240-208/120 VAC; 50/60Hz; factory-installed 4 ft. (121.9 cm) flexible steel conduit 3-wire conduit with a No. 10 ground wire; located on the right rear corner of unit	
Maximum Amp Usage	240V—36.6 amps (8.8 kW) 208V—31.7 amps (6.6 kW)	240V—45.0 amps (10.8 kW) 208V—38.9 amps (8.1 kW)
Surface Element Rating Right front Right rear Center front Center rear Left front Left rear Bridge	8.5" (21.6 cm) - 1,800 watt 8.5" (21.6 cm) - 1,800 watt N/A N/A 12" (30.5 cm) triple - 1,100 watt/1,000 watt/1,100 watt 6.5" (16.5 cm) - 1,200 watt 800 watt	6.5" (16.5 cm) - 1,200 watt 8.5" (21.6 cm) dual - 1,000 watt/1,000 watt 8.5" (21.6 cm) - 1,800 watt 8.5" (21.6 cm) - 1,800 watt 12" (30.5 cm) triple - 1,100 watt/1,000 watt/1,100 watt 6.5" (16.5 cm) - 1,200 watt 800 watt
Approximate Shipping Weight	44 lb. (20.0 kg)	53 lb. (24.1 kg)

Please do not prepare installation from brochure data only. See installation instructions for important clearance/installation information.

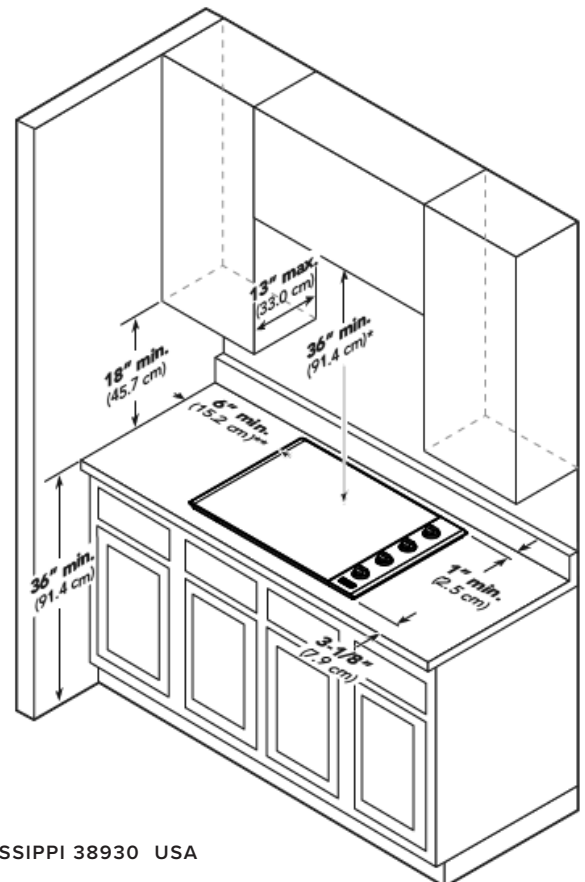
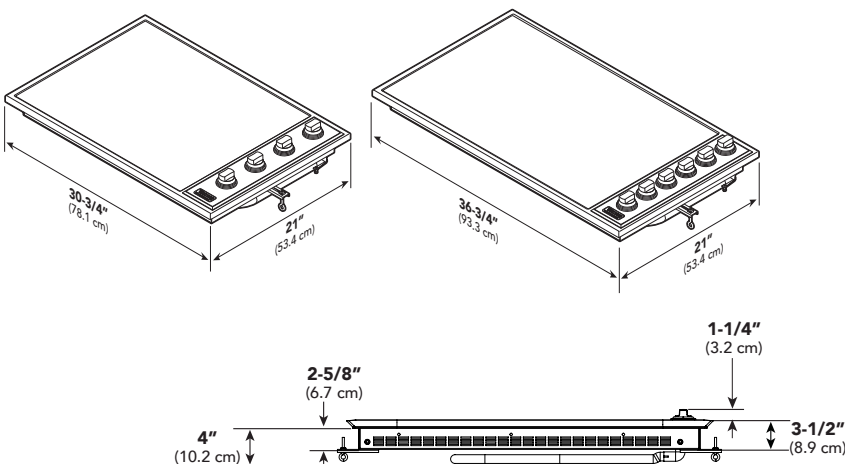

	30"W. Model	36"W. Model
A	28-7/8" (73.3 cm) min. to 29-1/8" (74.0 cm) max.	34-7/8" (88.6 cm) min. to 35-1/8" (90.8 cm) max.
B	19-1/4" (48.9 cm) min. to 19-3/4" (50.2 cm) max.	

Note: Based on 24" deep cabinet with 3/4" backsplash

CAUTION
Be sure the electric power is off from the breaker box to the junction box until the cooktop is installed and ready to operate. The junction box should be connected to a suitable ground.

WARNING
The electrical power to the unit must be shut off while lin connections are being made. Failure to do so could result in injury or death.



VIKING RANGE, LLC 111 FRONT STREET GREENWOOD, MISSISSIPPI 38930 USA

For detailed product information, model numbers, or to request a quote call 1-888-845-4641 or visit vikingrange.com

© 2020 Viking Range, LLC All rights reserved. Specifications subject to change without notice.