



## BUILT-IN 30"W. FULL-HEIGHT WINE CELLARS

*Viking Professional 5 Series – VCWB*

### PROFESSIONAL FEATURES

- Exclusive TriTemp™ Storage System provides three independent temperature zones
  - Preserves different types of wine at optimal serving temperatures
  - Settings are adjustable in each zone from 43 to 65 degrees F (6 to 18 degrees C)
- Electronic control center constantly monitors and maintains the set temperature in each zone within 1 degree F (0.83 degree C)
- Exclusive glass control pad
- 15 shelves accommodate up to 150 full-size wine bottles horizontally, keeping corks moist
  - Stores standard, magnum, and half-size bottles
  - Full-width shelves pull out for easy access and are fully removable for easy cleaning
  - Exclusive – two convertible wine shelves adjust for bottle display, and are excellent for allowing bottles to settle before serving
  - Shelves are coated to reduce vibration and hold bottles snugly in place
- Solid maple facings may be finished to coordinate with surrounding cabinetry
- Maintains constant 60% humidity level
- Ultraviolet-resistant tempered-glass and black interior protects wine from harmful light
- Lower zone has raised maple facings for additional ultraviolet protection
- Low-intensity interior lighting
  - Displays wine with minimal heat and light output
  - Turns on when door is opened or by switch
- High-temperature and open-door alarms may be connected to a home security system
- Keyed lock on door provides extra security

### EASY MAINTENANCE AND CLEANUP

- Removable shelves and upper grille for easy cleaning



- Power interruption switch completely turns off power to unit for safe cleaning and light tube replacement
- Front-venting sealed refrigeration system works silently and efficiently
- Adjustable-height lower kickplate removes to provide easy access to evaporator pan

### PROFESSIONAL-STYLE CONSTRUCTION

- Design and basic dimensions provide built-in appearance with standard cabinetry
- Dual-magnet/spring-assist door seal system automatically closes wine cellar door
- Door stops are factory set at 110 degree swing; easily adjust to 90 or 120 degree swing
- Must be ordered either right- or left-hinge (specify R or L after model number)

### MODEL NUMBERS

- VCWB301(R/L)SS – 30"W. Wine Cellar

### DESIGN OPTIONS

- Order as right or left hinge
- Professional stainless steel side panel kits
- Stainless steel top kit

### COLOR FINISHES

- Available in Stainless Steel (SS)

### WARRANTY

- 2-year full covers complete unit
- 6-year full – sealed refrigeration system
- 90-day full – cosmetic parts such as glass, painted items, and decorative items
- 12-year limited – sealed refrigeration system



# BUILT-IN 30"W. FULL-HEIGHT WINE CELLARS

Viking Professional 5 Series – VCWB

30" W. FULL-HEIGHT WINE CELLAR	
DESCRIPTION	VCWB301
Overall Width	30" (76.2 cm)
Overall Height	82-3/4" (210.2 cm) minimum; 84 1/16" (213.5 cm) maximum
Overall Depth from Rear	To rear of side trim – 22-3/16" (56.4 cm) To front of top grille – 24-1/2" (62.2 cm) To front edge of handle – 27" (68.6 cm)
Cutout Width	29-1/2" (74.9 cm)
Cutout Height	82-7/8" (210.5 cm) minimum; 84 1/16" (213.5 cm) maximum
Cutout Depth	24" (61.0 cm)
Electrical Requirements	115VAC/60Hz; 5' (152.4 cm), 3-wire cord with grounded 3-prong plug attached to product
Maximum Amp Usage	2.0 amps
Maximum Storage Capacity	150 bottles
Approximate Shipping Weight	157 lb. (71 kg)

Please do not prepare installation from brochure data only. See installation instructions for important clearance/installation information.

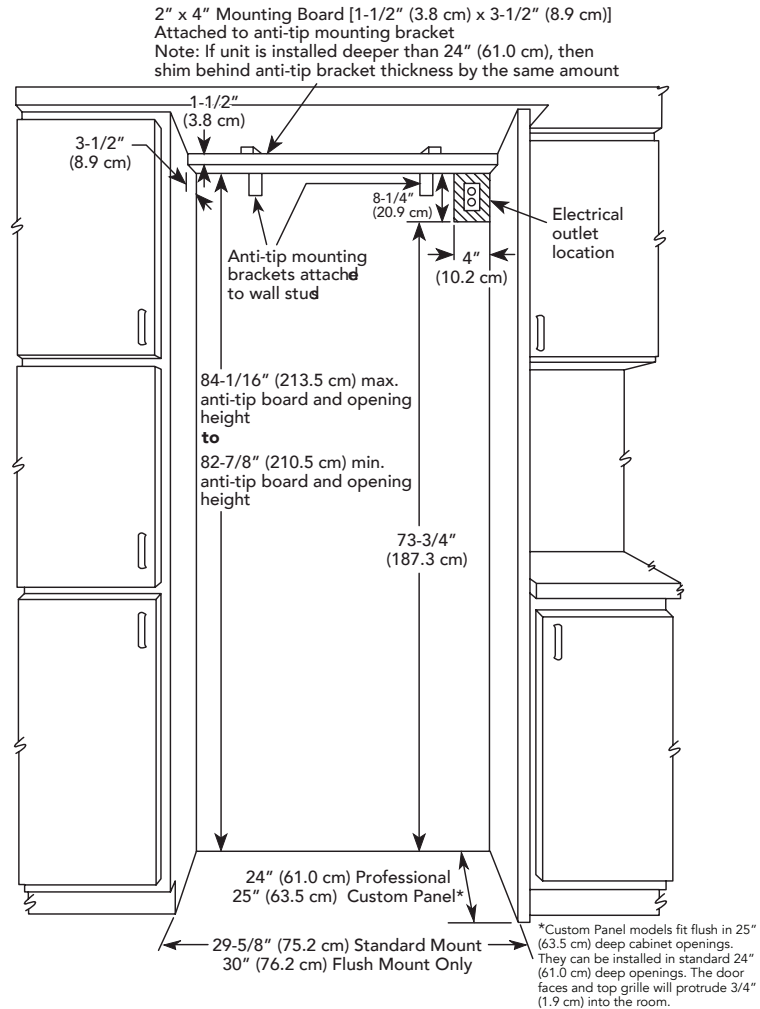
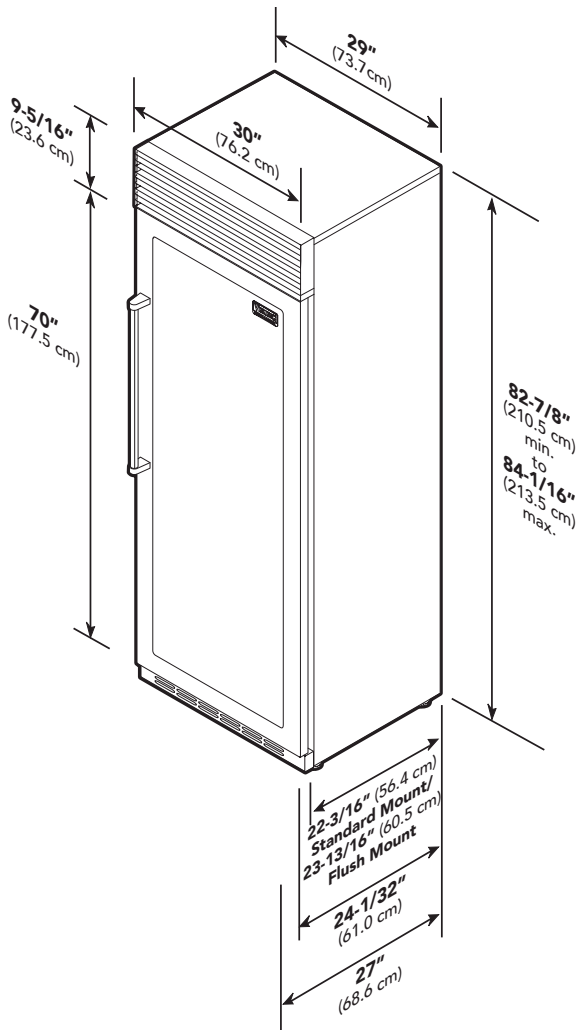

\*Custom Panel models fit flush in 25" (63.5 cm) deep cabinet openings. They can be installed in standard 24" (61.0 cm) deep openings. The door faces and top grille will protrude 3/4" (1.9 cm) into the room.



VIKING RANGE, LLC 111 FRONT STREET GREENWOOD, MISSISSIPPI 38930 USA

For detailed product information, model numbers, or to request a quote call 1-888-845-4641 or visit [vikingrange.com](http://vikingrange.com)

© 2017 Viking Range, LLC All rights reserved. Specifications subject to change without notice.